

TEACHING THE TRC SERIES CHANGER

The TRC Series Coin Changer are factory preset to maximize valid coin acceptance. However periodic adjustments may be required to correct frequency differences that can occur when the Acceptor / Gate Assembly and / or the Control Board / Backplate Assembly are replaced. Because of a special changer feature, no special equipment is required for teaching. All teaching procedures can be performed using coins only.

PREPARATION If teaching is required, follow these steps *before* beginning the actual teaching procedure:

- Interrupt power to the changer by removing the changer Power Plug.
- Lower the Acceptor / Gate Assembly
- Set the changer option switches as follows:

Changer Model TRC-6000xx* / TRC-6010xx*		
Switch	Condition	Meaning
1	ON	US / Canadian Acceptance
2	OFF	High 25¢ Sensor
3	ON	accept \$ coin
4	ON	\$ coin accept without 25¢ in tube

Changer Model TRC-6200xx*		
Switch	Condition	Meaning
1	ON	accept \$ coin
2	OFF	Accept 25¢ with Exact Change ON
3	either OFF or ON	escrow return
4	either OFF or ON	Dataguard

Changer Model TRC-6510		
Switch	Condition	Meaning
1	ON	US / Canadian Acceptance
2	OFF	High 25¢ Sensor
3	ON	\$ coin acceptance
4	OFF	maximum acceptance

Changer Model TRC-6512		
Switch	Condition	Meaning
1	OFF	High 25¢ Sensor
2	ON	\$ coin acceptance
3	OFF	maximum acceptance

Changer Model TRC-6800xx*		
Switch	Condition	Meaning
1	ON	\$ coin acceptance
2	ON	US / Canadian Acceptance
3	OFF	High 25¢ Sensor
4	ON	High level bill validator interface
5	ON	Escrow return
6	OFF	Escrow to Vend capability

NOTE: on unit with the **CIGARETTE SWITCH**, this switch must be **OFF**

* The letters in the XX position are variations of the changer

- Short the two teaching pins (upper set of pins on TRC6800) by touching both simultaneously with the tip of a conductive screwdriver (See FIGURES 1, 2, 3 or 4).

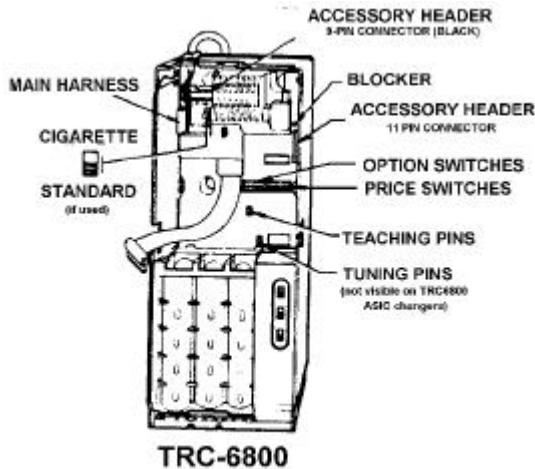

FIGURE 1: Location of teaching pins TRC-6800 TRC-6200

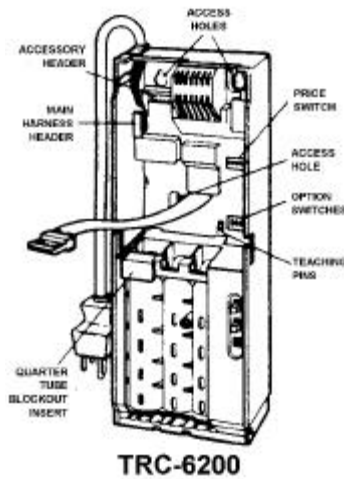

FIGURE 2: Location of teaching pins

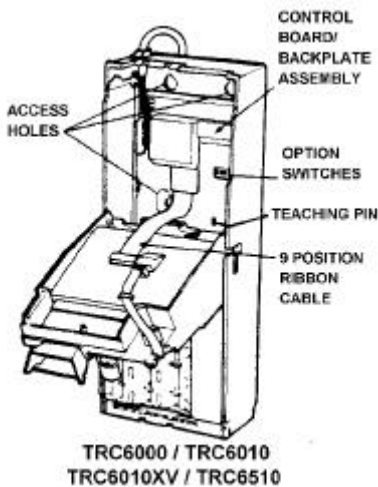

FIGURE 3: Location of teaching pins TRC-6000/6010 TRC-6010XV and TRC-6510 changers

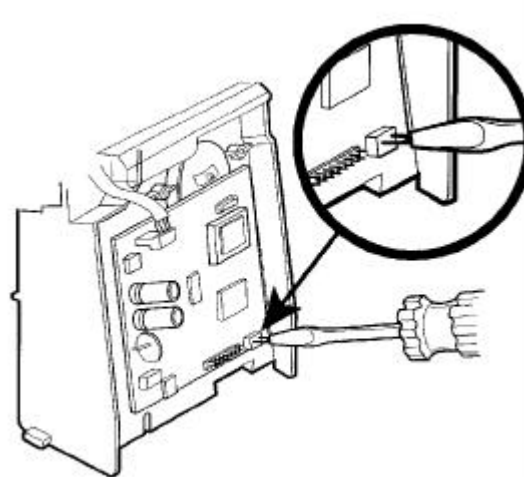

FIGURE 4: Location of teaching pins TRC-6512

- With the screwdriver still touching the teaching pins, re-instate power to the changer.
- Remove the screwdriver.
- Press the Acceptor / Gate Assembly back into position until the spring clips engaged.

The changer is now in the Teaching Mode.

TEACHING

In the teaching mode, the changer is taught to recognize a set of coins. These coins are placed into eight **(8)** different teaching locations, ten **(10)** on **TRC-6510** and **TRC-6512** changers, - two locations per each denomination coin (**nickel, dime, quarter, dollar, 2 tokens for TRC-6510 and TRC-6512**). Depressing the coin return lever during the teaching procedure skips a teaching location.

After teaching, the changer switches to a calibration mode. This mode serves as a fine-tuning function. To calibrate, insert 20 coins of each denomination (following the teaching order) into the changer. Acceptance may be poor at first. However, it will improve with the number of coins inserted.

NOTE: When doing the step described above on a vending machine that the highest programmed vend price will cause the changer to stop accepting coins once the highest vend price has been met or exceeded. At this time, will have to stop to make a vend at this time or interrupt power.

U.S. Coin Set

As shipped from the factory, the coin changers are programmed to accept U.S. coins only. If U.S. only acceptance is desired, follow the "U.S. Coin Set" procedure. These changers, however, can be taught to accept U.S. / Canadian coins. (Refer to "U.S. / Canadian Coin Set" instructions.)

U.S. COIN SET PROCEDURE

5 cents	1. insert first U.S. nickel	2. Insert second U.S. nickel
10 cents	3. insert first U.S. dime	4. Insert second U.S. dime
25 cents	5. insert first U.S. quarter	6. Insert second U.S. quarter
\$1 dollar coin	7. insert first U.S. dollar coin (if not wanted DEPRESS COIN RETURN LEVER)	8. Insert second U.S. dollar coin (if not wanted DEPRESS COIN RETURN LEVER)
NOTE: for TRC-6510, 6512 changers only		
token	9. insert first token (if not wanted DEPRESS COIN RETURN LEVER)	10. insert second token (if not wanted DEPRESS COIN RETURN LEVER)

TEACHING (con't)

1. Insert (1) US nickel; it will be rejected.
2. Insert second US nickel; it will be rejected.
3. Insert (1) US dime; it will be rejected.
4. Insert second US dime; it will be rejected.
5. Insert (1) US quarter; it will be rejected.
6. Insert second US quarter; it will be rejected.
7. Insert (1) Susan B. Anthony dollar coin; it will be rejected.
8. Insert second Susan B. Anthony dollar coin; it will be rejected.
9. On TRC-6510 or TRC-6512 only, Insert (1) token; it will be rejected.
10. On TRC-6510 or TRC-6512 only, Insert second token; it will be rejected.
11. Calibrate changer by dropping (20) coins of each denomination into the changer in the same order as above.

NOTE 1: To skip channel, depress and release the coin return lever

NOTE 2: On the TRC-6510, TRC-6512 and TRC-6800 models only, the nickel dispenser should cycle once after step 8 on TRC-6800 or step 10 on TRC-6510, TRC-6512.

TEACHING COMPLETE

U.S. / Canadian Coin Set

As shipped from the factory, Models with a "C" immediately following the model number (I.E. TRC-6xxxCx) are programmed to accept U.S. and Canadian coins. To tune a changer for U.S. and Canadian coins follow this procedure.

U.S. / CANADIAN COIN SET PROCEDURE

5 cents	1. insert one U.S. nickel	2. Insert one Canadian nickel (Post 1983 only)
10 cents	3. insert one U.S. dime	4. Insert one Canadian dime
25 cents	5. insert one U.S. quarter	6. Insert one Canadian quarter
\$1 dollar coin	7. insert first U.S. dollar coin (if not wanted DEPRESS COIN RETURN LEVER)	8. Insert one Canadian dollar coin (if not wanted DEPRESS COIN RETURN LEVER)
TRC-6510 and TRC-6512 changers only		
token	9. insert first token (if not wanted DEPRESS COIN RETURN LEVER)	10. insert second token (if not wanted DEPRESS COIN RETURN LEVER)

1. Insert (1) US nickel; it will be rejected.
2. Insert (1) Canadian nickel (Post 1983 only); it will be rejected.
3. Insert (1) US dime; it will be rejected.
4. Insert (1) Canadian dime; it will be rejected.
5. Insert (1) US quarter; it will be rejected.
6. Insert (1) Canadian quarter; it will be rejected.
7. Insert (1) Susan B. Anthony dollar coin; it will be rejected.
8. Insert (1) Canadian dollar coin; it will be rejected.
9. On TRC-6510 and TRC-6512 only, Insert (1) token; it will be rejected.
10. On TRC-6510 and TRC-6512 only, Insert second token; it will be rejected.
11. Calibrate changer by dropping (20) coins of each denomination into the changer in the same order as above.

NOTE 1: On the TRC-6510, TRC-6512 and TRC-6800 models only, the nickel dispenser should cycle once after step 8 on TRC-6800 or step 10 on TRC-6510 or TRC-6512.

TEACHING COMPLETE

NOTE: the TRC product does not accept the two dollar coin due to its size.