

# SERIES 2000

## Operation and Service Guide



VN 2300  
VN 2500



---

---

# Table Of Contents

## General Information

Overview.....	1
Features.....	1
Model # Configuration.....	2
Serial # Configuration.....	2
Bezel Styles.....	3
Magazine Styles.....	4
Cables.....	5
Specifications.....	6
Interfaces.....	6

## Installation

Unpacking the Bill Acceptor.....	7
Warranty.....	7
Configuration.....	8
Factory Configuration.....	8
Switch Settings.....	9 - 11
VFM3 Switch Conversion.....	12
Coupon Configuration.....	12 - 14
Single Price Coin Mech Installation.....	15
Mounting.....	16

---

---

# Table Of Contents

Testing.....	16
--------------	----

## Operation

Functional Overview.....	17
--------------------------	----

## Interfaces

General.....	18
IHLP.....	19
ILLP.....	19
NILLP.....	20
NISR.....	20
MDB.....	21

## Maintenance

Cleaning.....	22
Status LED.....	23

## Connector Pinouts

Connector Pinouts.....	24
Mating Onnectors.....	24

---

---

# General Information

## Overview

The Series 2300/2500 Operation and Service Guide contains important information on installing, operating, and maintaining Mars Electronics Bill Acceptors models VN2300 and VN2500. The Series 2300/2500 Bill Acceptors take currency at high acceptance rates and provide a superior level of resistance against specific cheats and frauds.

To obtain the best performance from your Mars Electronics Bill Acceptor, read this manual and the Installation Guide before installing and using the bill acceptor.

## Product Summary

The VN2300 model of the Series 2300/2500 is designed for vending applications using US \$1 and \$2 dollar bills. It offers enhanced security, one- and two-way acceptance of bills.

The VN2500 model of the Series 2300/2500 is designed for vending applications using US \$1, \$2, and \$5 dollar bills. It offers enhanced security, and one-, two-, and four-way acceptance of bills. A cash counter interface provides optional audit data (110V units only).

## VN2300/VN2500 Comparison Chart

<i>Attribute</i>	<i>VN2300</i>	<i>VN2500</i>
<i>Bills Accepted</i>	<i>\$1, \$2</i>	<i>\$1, \$2, \$5</i>
<i>Direction</i>	<i>1 and 2 way</i>	<i>1, 2, and 4 way</i>
<i>Configuring</i>	<i>Option switches</i>	<i>Option switches and coupon</i>
<i>Cash counter</i>	<i>No</i>	<i>Yes (110VAC units only)</i>
<i>Interfaces</i>	<i>ILLP, IHLP, MDB</i>	<i>ILLP, IHLP, NILLP, MDB, NISR, NILL.</i>

**Note: See page 6 for description of Interface Acronyms.**

## Series 2000 Features

- Easy access to entire bill path with unit installed in machine
- High acceptance of US currency
- Returned or rejected bills held in bill acceptor mouth until removed by customer
- Coupon configuration for easy option programming (VN2500 only)

- MDB interface on 24V units
- Smart serial interface on 110V and 24V units (VN2500 only)
- Choice of three different bezel styles
- Sealed optical sensors to enhance security and reduce effects of vandalism
- Status LED on back of unit to indicate current state of operation
- Designed for ease of maintenance

### Model Number Configuration

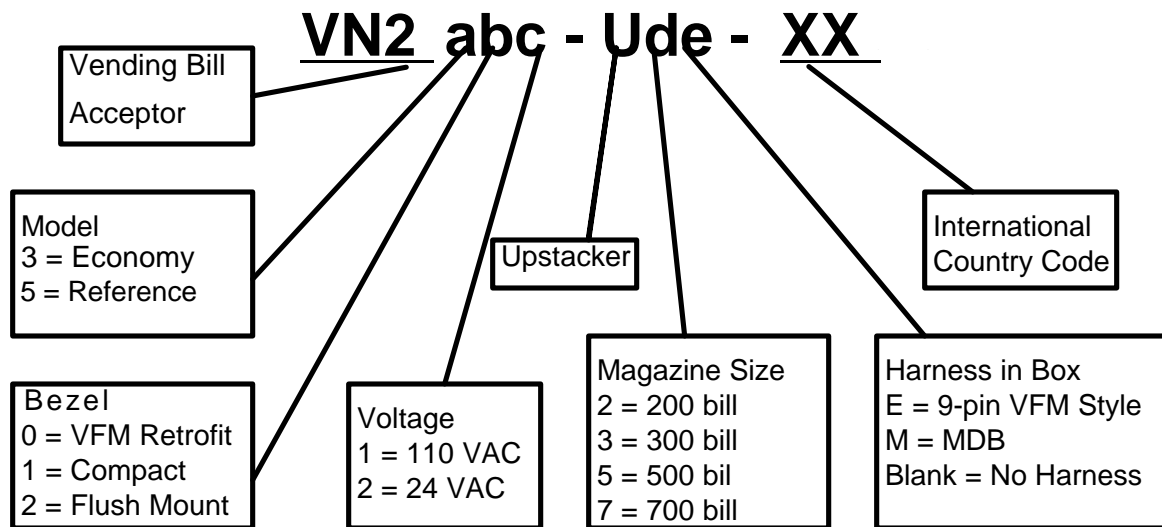

### Serial Number Configuration

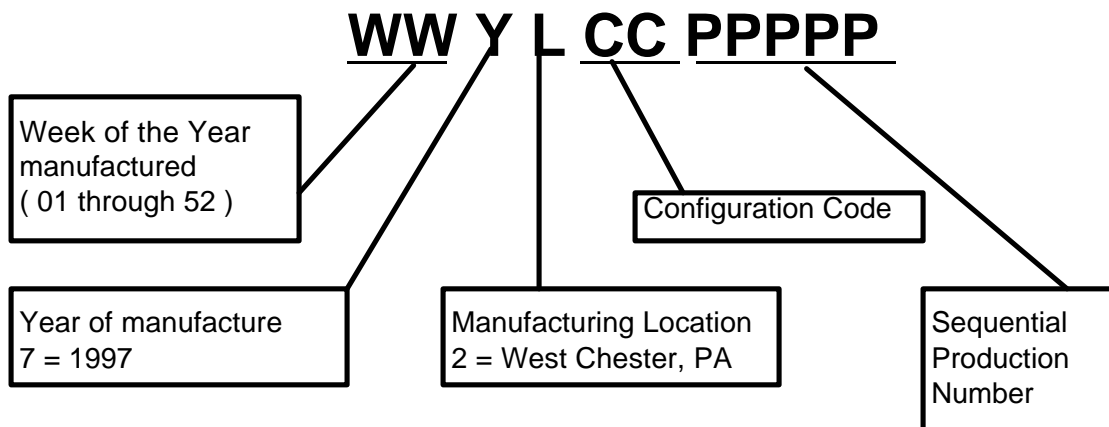

## General Information

---

### Bezel Styles

The Series 2300/2500 offers three different bezel configurations: Compact, VFM Retrofit, and Flush Mount.

The Compact bezel allows for ease of bill insertion with lighted arrows pointing to the place of insertion.

The VFM Retrofit bezel is modeled after the familiar bezel from the VFM Series Bill Acceptor. Dimensions are the same as the standard VFM Series bezel.

The Flush Mount bezel has decreased face depth enabling it for use in specific applications that require special mounting provisions.

### Bezel Conversion Kits

Bezel Conversion Kits are available to convert from one bezel style to another. Part numbers for the bezel conversion kits are as follows:

To Convert to:	Use Conversion Kit:
Compact Bezel	250065014 (Compact Conversion Kit)
VFM Retrofit Bezel	250067013 (VFM Retrofit Conversion Kit)
Flush Mount Bezel	250069012 (Flush Mount Conversion Kit)

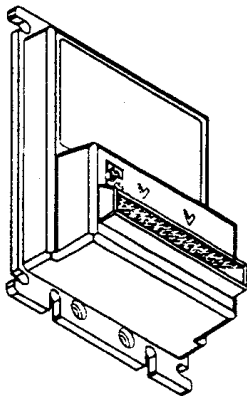

**Figure 1**  
**Compact Bezel**  
Part No. 250011005  
Used on VN251x-Uxx

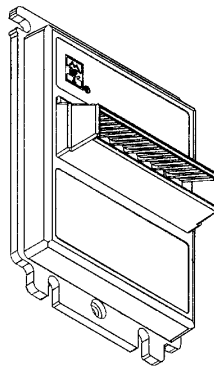

**Figure 2**  
**VFM Retrofit Bezel**  
Part No. 250023053  
Used on VN250x-Uxx

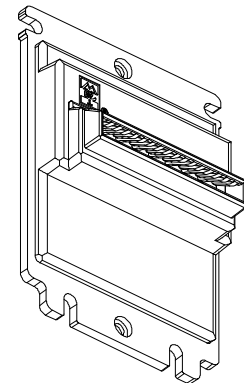

**Figure 3**  
**Flush Mount Bezel**  
Part No. 250022067  
Used on 252x-Uxx

## Magazine Styles

Four different magazine sizes are available for the Series 2300/2500 bill acceptors. Magazine capacities of 200, 300, 500, and 700 bills are available.

- The 200 and 300 bill magazine styles feature a hinged *top* door for bill removal.
- The 500 and 700 bill magazine styles use hinged *side* doors for bill removal.

If necessary, you can easily remove all magazine styles from the bill acceptor for another method of bill removal.

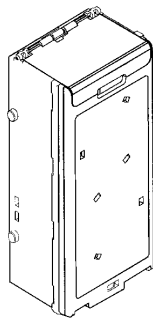

**Figure 4**  
**200 Bill Magazine**  
**Part No. 250063015**  
**Used on VN2xxx-U2x**

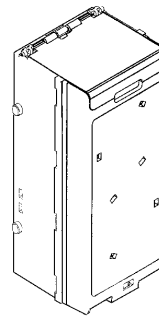

**Figure 5**  
**300 Bill Magazine**  
**Part No. 250061016**  
**Used on VN2xxx-U3x**

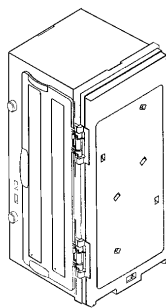

**Figure 6**  
**500 Bill Magazine**  
**Part No. 250069017**  
**Used on VN2xxx-U5x**

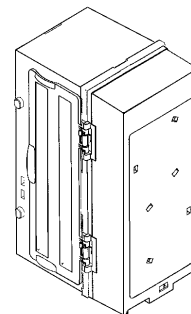

**Figure 7**  
**700 Bill Magazine**  
**Part No. 250068021**  
**Used on VN2xxx-U7x**

## General Information

---

### Cables

#### 110VAC Power Cable

Part Number 250077006

Used on VN2xx1-UxE

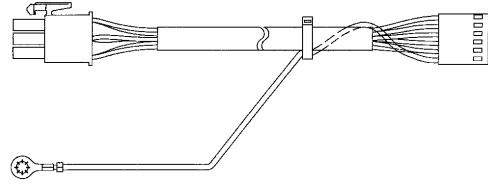

#### 24VAC Power Cable

Part Number 250075007

Used on VN2xx2-UxE

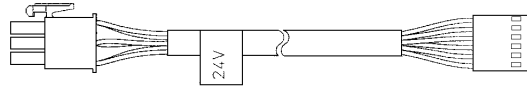

#### MDB Cable

Part Number 250071009

Used on VN2xx2-UxM

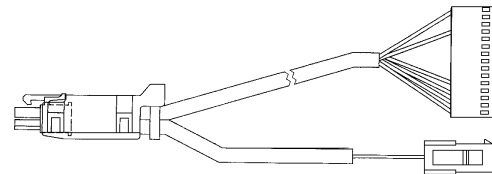

#### 18 Pin Extension Cable

Part Number 250072012

Used to extend 18 pin interface connector (10" long)

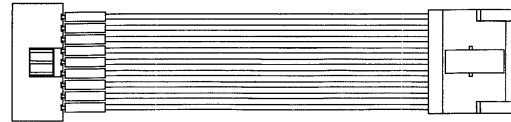

#### Enable Jumper Cable

Part Number 250074011

Used to enable \$1, 2, and 5 bills for stand-alone applications

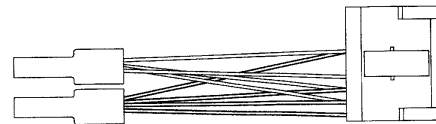

#### Low Level Interface Cable

Part Number 250070013

Used on VN2xx1-UxE

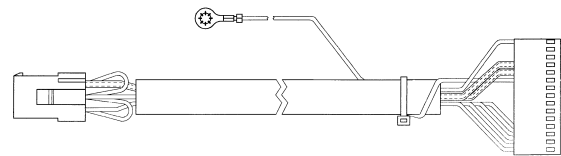

#### High Level Interface Cable

Part Number 250072017

Used on VN2xx1-UxE

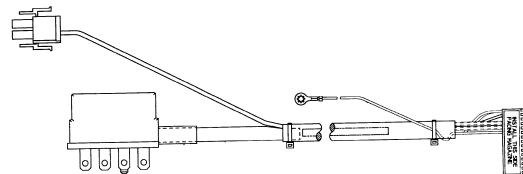



## Specifications

### Power

The Series 2300/2500 is available as either a 24VAC or a 115VAC unit.

The 24VAC unit may be powered with 24VDC (MDB mode).

Power ratings for the units are:

- 110VAC / 60 cycles at 0.5 amps
- 24VAC / 60 cycles at 2.0 amps
- 34 VDC at 2.0 amps (MDB mode)

### UL Listing

The Series 2300/2500 is listed under UL File # E57869

## Interfaces

The VN2300 supports the following interfaces:

- Isolated High Level Pulse (IHLP)
- Isolated Low Level Pulse (ILLP)
- Multi-Drop Bus (MDB)

The VN2500 supports the following interfaces:

- Isolated High Level Pulse (IHLP)
- Isolated Low Level Pulse (ILLP)
- Non-Isolated Low Level Pulse (NILLP)
- Non-Isolated Low Level (NILL - Credit Line)
- Non-Isolated Serial (NISR)
- Multi-Drop Bus (MDB)

See *Interfaces* on page 18 for a detailed description of each type of interface.

---

---

# Installation

## Unpacking the Bill Acceptor

Unpack the bill acceptor and immediately inspect it for damage. If the unit is damaged, return it to its original carton along with packing materials.

Notify the delivering carrier of damages and request immediate inspection. Send a letter of intent to file a claim to the delivering carrier within 72 hours from the time of delivery. Send a copy of the letter to the shipper.

Only the consignee (the person or company receiving the bill acceptor) can file a claim against the carrier for concealed damages.

Retain the original carton and packing materials for future use in shipping or transporting the bill acceptor.

## Warranty

**All Series 2000 Bill Acceptors come with a Two Year Manufacturer's Warranty.** Once the unit has been inspected, record the model and serial numbers from the label on the side of the bill acceptor. Refer to these numbers when you call Mars Electronics for service or information. The manufacturer's warranty is based upon the date of manufacture. Parts and labor are included for In Warranty repairs.

The first three digits of the serial number contain the manufacturing date code. (See *Serial Number Configuration* on page 2.) This code indicates the beginning of the warranty period. The first two digits indicate the week of manufacture; the third digit indicates the year of manufacture. For example: a bill acceptor with a serial number of 30720033333 was manufactured in the 30th week of 1997 (July 1997).

---

## Configuration

The VN2300 and VN2500 can be manually configured using a bank of eight option switches. The VN2500 can also be configured using a configuration coupon.

### Factory Configuration

The Series 2300/2500 Bill Acceptor is factory configured with all switches in the OFF position. The following configuration is programmed:

- Maximum directions for bill acceptance (two-way for VN2300, four-way for VN2500)
- High security
- \$1 bill enable only (VN2300/2500)
- 1 pulse per dollar
- Short Pulse Timing enabled (30 ms on/ 50 ms off)

***Note: all VN2500 Bill Acceptors manufactured prior to week 8 of 1997 will have a Factory Configuration of \$1, \$2, and \$5 Bills.***

The unit will default to these selections whenever all option switches are OFF. Placing any switch ON will override the factory settings and the bill acceptor will operate according to the switch settings you choose.

If the VN2500 is reprogrammed using a coupon with a different configuration, the new configuration will be the default. If any option switch is turned ON, the option switch settings will override the coupon setting. The coupon configuration will remain in memory.

## Switch Settings

The Series 2300/2500 allows configuration of interface options through option switch selection. The option switches are located on the right-hand side of the bill acceptor (see option switch labels in Figures 8 and 9). The next two pages described how the option switches work.

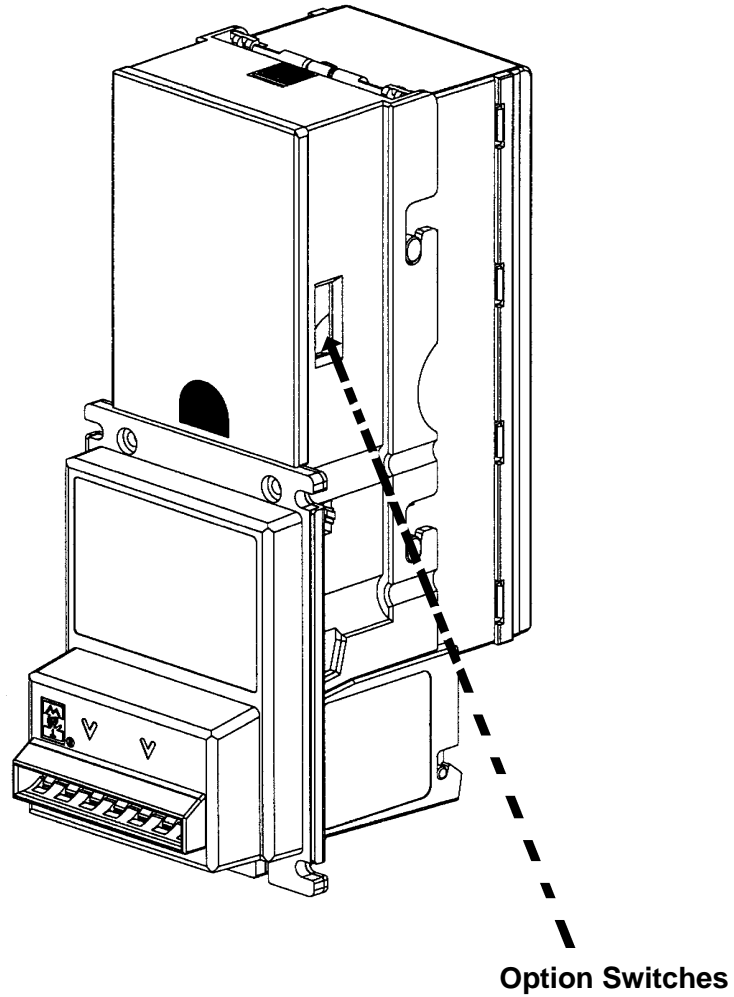

VN2300 Switch Settings

<b>Switches 1 and 2</b>			<b>Factory Default</b>
<i>Switch 1</i>	<i>Switch 2</i>		
ON	OFF	1 way bill acceptance	
OFF	ON	2 way bill acceptance	X
<b>Switch 3</b>			
ON	High security		X
OFF	High acceptance		
<b>Switch 4</b>			
ON	Accept \$1 bills		X
OFF	Reject \$1 bills		
<b>Switch 5</b>			
ON	Accept \$2 bills		
OFF	Reject \$2 bills		
<b>Switches 6, 7 and 8</b>			
<i>Unassigned</i>			

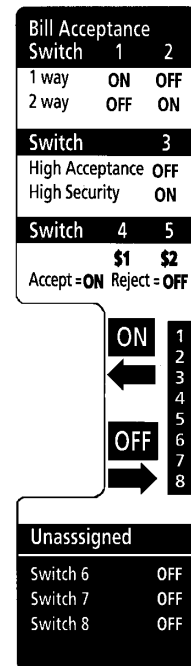
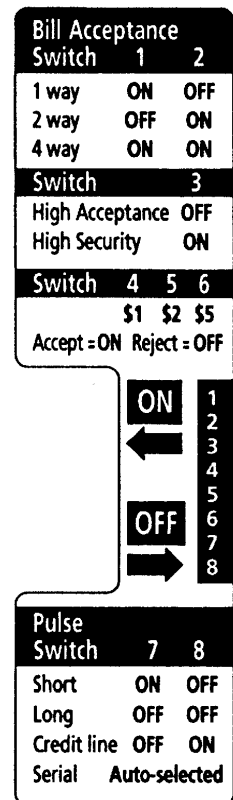

**Figure 8**  
VN2300 Switch Settings

Installation

**VN2500 Switch Settings**

<b>Switches 1 and 2</b>			<b>Factory Default ***</b>
Switch 1	Switch 2		
ON	OFF	1 way bill acceptance	
OFF	ON	2 way bill acceptance	
ON	ON	4 way bill acceptance	X
<b>Switch 3*</b>			
ON	High security		X
OFF	High acceptance		
<b>Switch 4</b>			
ON	Accept \$1 bills		X
OFF	Reject \$1 bills		
<b>Switch 5</b>			
ON	Accept \$2 bills		
OFF	Reject \$2 bills		
<b>Switch 6</b>			
ON	Accept \$5 bills		
OFF	Reject \$5 bills		
<b>Switches 7 and 8 **</b>			
Switch 7	Switch 8		
ON	OFF	Short pulse - 30 ms ON / 50 ms OFF timing	X
OFF	OFF	Long pulse - 35 ms ON / 300 ms OFF timing	
OFF	ON	Credit line - single 150 ms pulse	
<p>* Switch 3 affects all denominations. See <i>Coupon Configuration</i> on page 13 for individual acceptance/security enabling options.</p> <p>** If you are connecting the unit to a serial or MDB interface, turn switches 7 and 8 OFF before connecting the harness. Once power is applied, the unit will recognize the serial or MDB interface and will ignore switches 7 and 8.</p> <p>*** Units manufactured after week 8, 1997.</p>			



**Figure 9**  
**VN2500 Switch Settings**

**VFM3 Switch Conversion**

If you are familiar with the VFM3 switch settings for a machine, the following table will assist you in your interface timing selection for the Series 2300/2500. The settings of 2, 6, and 7 on the VFM3 correspond to settings on switches 7 and 8 on the VN2500.

<b>Interface Timing Conversion</b>					
<b>VFM3 Settings</b>			<b>Interface/ Timing</b>	<b>VN2500 Settings</b>	
Switch 2	Switch 6	Switch 7		Switch 7	Switch 8
ON	ON	ON	<b>Short</b>	ON	OFF
OFF	ON	ON	<b>Long</b>	OFF	OFF
OFF	OFF	ON	<b>Credit Line</b>	OFF	ON
OFF	OFF	OFF	<b>Serial</b>	AUTO - SELECTED	
NOT SUPPORTED ON VFM			<b>MDB</b>	AUTO - SELECTED	

**Coupon Configuration**

The VN2500 may be configured using a coupon. The coupon is included in the VN2500 Series Installation Guide. Carefully cut the coupon along the dotted-line edge to remove it from the installation guide. Copies of the original coupon may be produced with a standard, carbon-based, non-color copier. Cut copies to match the size of the original coupon.

**All option switches must be in the OFF position for the coupon selections to be active.**

The coupon selection will remain with the VN2500 until the unit is reprogrammed, even if power is removed.

When filling out the coupon, note the following:

- Use only a #2 pencil to fill in the blocks
- Fill in the entire block
- Do not mark the coupon outside the blocks or on the back of the coupon
- Fill in ONE block for EVERY line

**Figure 10**

## Installation

---

### Configuring with the Coupon (VN2500 Only)

1. Fill out the coupon using the table below. (Refer to Figure 15 for a sample coupon.)

<b>Section 1: # of Bill Directions</b>	One- and two-direction are face up only. Four-direction acceptance is available to maximize bill handling.
<b>Section 2: Denomination Selection</b>	Select ONE of the following for each bill denomination: <ul style="list-style-type: none"><li>• <b>High Accept</b> enhances acceptance parameters for the particular denomination.</li><li>• <b>High Security</b> enhances security parameters for the particular denomination.</li><li>• <b>OFF</b> rejects all inserted notes for the particular denomination.</li></ul>
<b>Section 3: Pulse</b>	The selection made in this section determines pulse timing. <ul style="list-style-type: none"><li>• <b>Short</b> is 30 ms ON / 50 ms OFF</li><li>• <b>Long</b> is 35 ms ON / 300 ms OFF</li><li>• <b>Credit Line</b> is a single 150 ms pulse on an individual denomination output. This selection is also used for AC / High Level Interface.</li></ul> <b>Serial and MDB</b> users may mark any selection.
<b>Section 4: Pulses per Dollar</b>	Select the required number of pulses per dollar. One pulse per dollar is standard for most interfaces.
<b>Section 5: Bezel Lights</b>	Select ON or Flashing for the bezel lights (downward arrows). This section applies only to the Compact bezel style. Select Flashing if the unit has a VFM Retrofit or a Flush Mount bezel style.



2. Locate the service button on the back of the unit (refer to Figure 11).
3. Press the button once to enter the coupon setup mode. Pressing again will exit the mode. The unit will automatically exit coupon setup mode upon acceptance of the coupon configuration.

The LED Status indicator (located to the left of the service button) will flash rapidly indicating that the unit is in coupon setup mode.

4. Insert the coupon marked-side up.

The VN2500 will pull the coupon in, read it, and then return it to the user.

- A good coupon will be returned immediately. After the coupon is pulled from the bill acceptor mouth, the unit will flash the Status LED ten times to confirm a good configuration.
  - A bad coupon will be held for ten seconds before being returned. This delay is to make you aware that there is a problem with the coupon. When the coupon is pulled from the bill acceptor mouth, the unit will flash the Status LED the number of times corresponding to the section of the coupon wherein a problem lies. For example, if the problem is in section five, the LED will flash five times. Section numbers are located to the far right of each section on the coupon.
5. If the configuration is rejected, check the coupon and repeat the process.

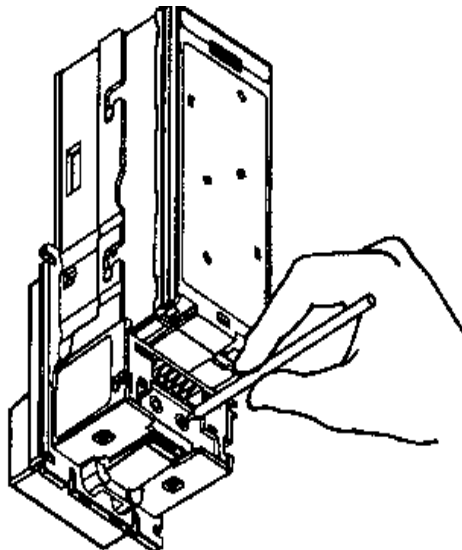

Figure 11

## Single Price Coin Changer Installation

**ELECTRICAL DAMAGE** will occur if an ARDAC T-Adapter harness is used with a MARS low-level harness (Part No. 01-12-065 or 112511008) to interface a MARS Bill Acceptor to a coin changer.

Remove the ARDAC T-Adapter and use the MARS Interface Harness alone.

Figure 12 below depicts the **incorrect** installation of interface harnesses which results in electrical damage.

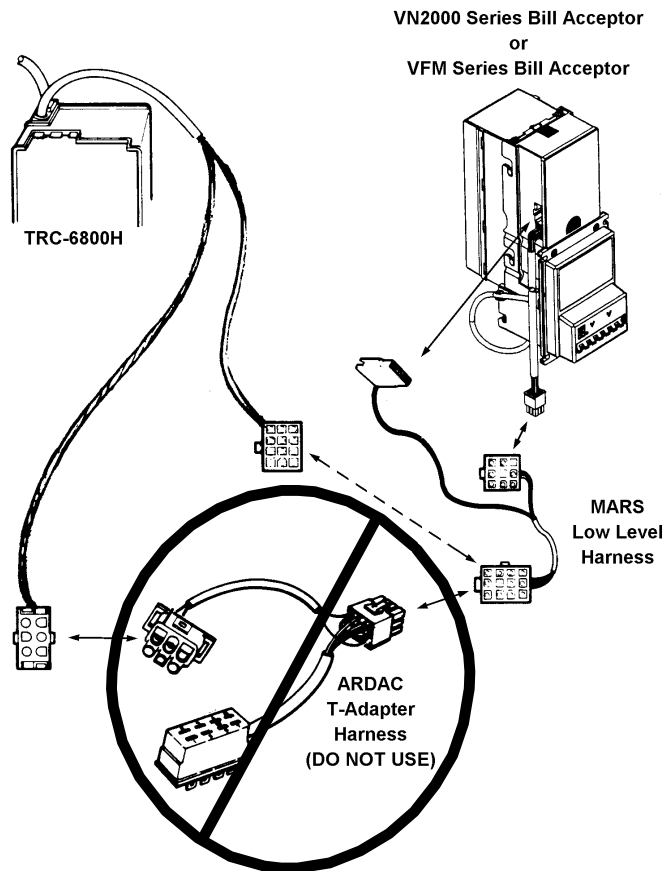

Figure 12

## Mounting

The Series 2300/2500 has been designed for ease of mounting onto existing studs provided by Original Equipment Manufacturers (OEMs). Some machines may require brackets or faceplates to mount the unit. Refer to your machine operation manual or contact your distributor/OEM for more model-specific mounting information.

The Series 2300/2500 has a tie-wrap included with each unit to secure its interface harness to the mounting area of the machine. Use the tie-wrap for every installation.

1. Disconnect all power to the machine.
2. Connect the interface harnesses from the machine to the unit.
3. ON 110VAC UNITS, install the ring terminal of the ground wire on the stud closest to the unit interface connector. *NOTE: 24VAC units do not have grounding wire.*
4. Wrap the tie-wrap around the interface harness. *Important Note To OEMs: Perform step 4 after Machine Dielectric Voltage - Withstand (Hi-Pot) Testing.*
5. Mount the tie-wrap to the stud (refer to Figure 13).
6. Secure the unit to the mounting studs with the appropriate hardware.

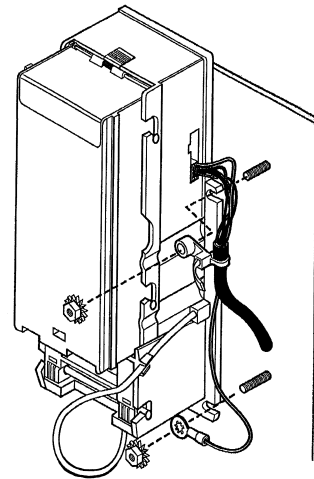

**Figure 13**

## Testing

1. Apply power to the machine.
2. Check the Status LED for the "Steady ON" condition. If another condition exists, refer to *Maintenance* on page 23 for troubleshooting details.
3. Insert a bill to check acceptance. If enabled, the bill should be accepted.
4. Make a vend to ensure proper credit is received and proper change is paid out for the bill.

---

# Operation

## Functional Overview

The acceptance of a bill in a Mars Electronics Bill Acceptor proceeds through the following steps:

- Bill Detection
- Bill Transport
- Bill Recognition
- Bill Validation
- Credit or Return
- Bill Storage

As a bill is inserted, the acceptor senses its presence and the drive motor is energized. Drive belts transport the bill past electronic sensors that evaluate the bill for authenticity.

When the unit determines that the bill is authentic, it holds the bill in an escrow position until the conditions of the transaction are determined. Conditions of the transaction include:

- Option selection
- Credit enabled by the controller
- Control system ready

When the conditions of the transaction are met, credit for the bill is transferred and the unit transports the bill to the end of the stacker where the actuator plate moves the bill into the magazine.

If the bill does not meet the criteria for authenticity or if the controller requests an escrow return, the bill acceptor will reverse the direction of the accept motor and will return the bill to the customer.

---

---

# Interfaces

## General

The interface of a bill acceptor refers to the transfer of electronic data to and from the bill acceptor and the controlling device. The controlling device in a vending machine is either the machine controller or the coin mechanism (single or four price machines). The signals transferred to the bill acceptor are control signals which may include:

- the control system is ready to accept money
- the denomination of bill to accept
- whether or not bills should be returned from escrow

The following interfaces are available with the Series 2300/2500.

<b>VN2300</b>	<b>VN2500</b>
IHLP	IHLP
ILLP	ILLP
MDB	NILLP
	NILL
	NISR
	MDB

**24VAC** units support Isolated High Level Pulse (IHLP), Isolated Low Level Pulse (ILLP), and Multi-Drop Bus (MDB) interfaces.

**110VAC** units support IHLP, ILLP, Non Isolated Low Level Pulse (NILLP), Non Isolated Serial (NISR), and Non Isolated Low Level (NILL) interfaces.

## IHLP - Isolated High Level Pulse

IHLP is also known as AC/High Level interface. Refer to Figure 14 for switch settings. This interface is available with the **VN2300 and VN2500**.

This interface uses the application of AC voltages for enabling and inhibiting a bill acceptor. Credit is established through single 150 ms "switch" closures (pulses). Bill escrow is not supported.

IHLP only supports \$1 bills.

A single coin tube is monitored for the presence of change in order to determine if an exact change condition exists. If such a condition exists, the exact change light will be turned ON and the bill acceptor will be inhibited; it will not pull the bill in.

Turn the coin changer (TRC6800H) option switch #4 ON when using High Level interface.

Use only harness part number 01-12-111-4 (single price) or 01-12-119-4 (four price) to connect a VN2300 or VN2500 to coin changers that use High Level interface.

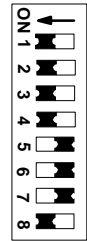

Figure 14

## ILLP - Isolated Low Level Pulse

ILLP is also known as Low Level interface. Refer to Figures 15 and 16 for switch settings. This interface is available with the **VN2300 and VN2500**.

This interface uses the application of isolated DC voltages for enabling and inhibiting a bill acceptor. Credit is established through long or short "switch" closures (pulses). Bill escrow is supported.

ILLP supports \$1 and \$2 for the VN2300 and \$1, \$2, and \$5 bills for the VN2500. Note that a vend price of \$2.75 or greater may be required for acceptance of a \$5 bill on a TRC-6800H/Single Price Changer.

All coin tubes are monitored to determine if an exact change condition exists. If an exact change condition exists, the exact change light will be turned ON after a bill has been inserted.

TRC6800H coin changers support this interface. Turn the coin changer option switch #4 OFF for this interface.

Use harness part number 01-12-065-4 or 112511008 to interface a VN2300 or VN2500 to coin changers that use Low Level interface.

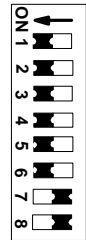

Figure 15  
Long Pulse

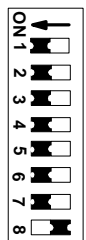

Figure 16  
Short Pulse

## NILLP - Non-Isolated Low Level Pulse

NILLP is also known as Credit Line. Refer to Figure 17 for switch settings. NILLP is available for the **VN2500 only**.

This interface uses the application of DC voltages for enabling and inhibiting a bill acceptor. Credit is established through 150 ms signals to individual denomination outputs. Escrow is supported.

NILLP supports \$1, \$2, and \$5 bills. Make sure an appropriate credit line input exists before you enable a corresponding bill denomination. For example, no credit will be established for a \$5 bill on a controller with no \$5 credit line.



**Figure 17**

All coin tubes are monitored to determine if an exact change condition exists. If an exact change condition exists, the exact change light will be turned ON after a bill has been inserted.

Electronic controllers use this interface. Refer to the operation guide provided with your machine for harness ordering information.

## NISR - Non-Isolated Serial (110VAC units *only*)

NISR is also known as Serial or SMART interface. Refer to Figure 18 for switch settings. NISR is available with the **VN2500 only**.

This interface uses the application of one-way data messages and DC handshaking voltages for communication between a controller and a bill acceptor.

NISR supports \$1, \$2, and \$5 bills with the VN2500.

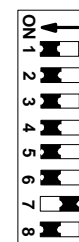

**Figure 18**

All coin tubes are monitored to determine if an exact change condition exists. If an exact change condition exists, the exact change light will be turned ON after a bill has been inserted.

Electronic controllers use this interface. Refer to the operation guide provided with your machine for harness ordering information.

## MDB - Multi-Drop Bus (24VAC units only)

Refer to Figure 19 for switch settings. This interface is available with the **VN2300** and **VN2500**.

This interface uses the application of a specific bi-directional serial interface protocol for communication between a controller and a bill acceptor.

MDB supports \$1, \$2, and \$5 bills with the VN2500 and \$1 and \$2 bills with the VN2300.

All coin tubes are monitored for the presence of change in order to determine if an exact change condition exists. If an exact change condition exists, the exact change light will be turned ON after a bill has been inserted.

An MDB interface harness (Part No. 250071009) is included with VN23x2-UxM and VN25x2-UxM units.

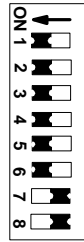

**Figure 19**



---

---

# Maintenance

## Cleaning

You can clean the bill acceptor while it is still mounted in the machine (refer to Figure 20 below).

1. Remove power from the machine.
2. Unlatch the magazine by pushing the blue latch (located on the top of the unit) toward the front of the unit.
3. Unhook and remove the magazine by holding the latch and lifting up and then back on the magazine.
4. Unlatch the LED Housing by lifting up on the metal bar (located below the Status LED).
5. Remove the LED Housing by holding the metal bar and pulling back on the LED Housing.
6. Clean the bill path with a soft cloth. You may use mild, non-abrasive, non-petroleum based cleaners if sprayed on the cloth.

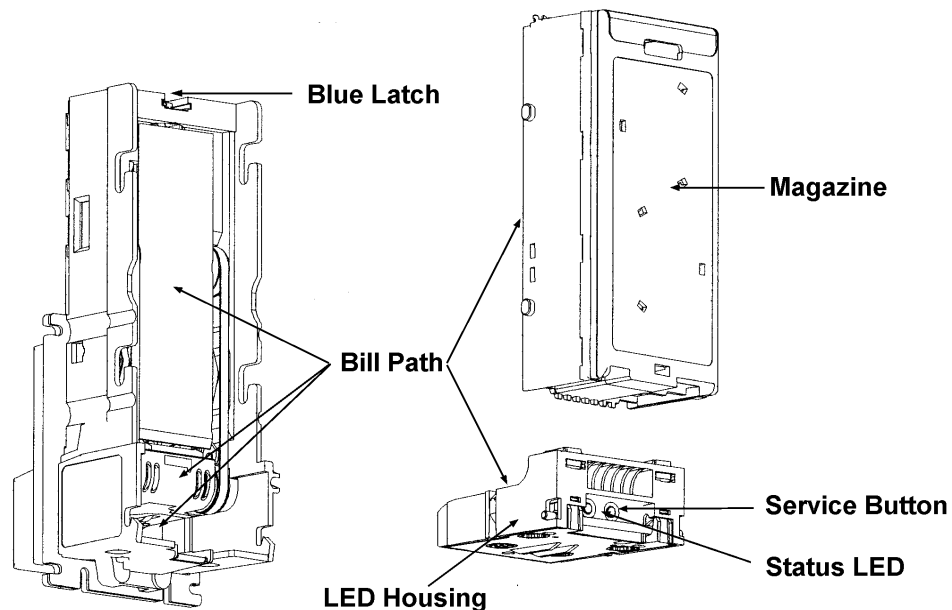

Figure 20

## Status LED

A Status LED provides assistance in diagnosing the condition of the Series 2300/2500. The following is a description of the LED codes, their meanings, and suggested remedial actions.

Signal	Meaning	Solution
<b>LED ON</b>	Indicates that the unit is enabled and ready to accept a bill.	No action necessary.
<b>LED OFF</b>	Indicates that no power has been applied to the unit.	Check to ensure that power is applied.
<b>1 Flash</b>	Indicates that something is obstructing the bill path.	Remove the magazine and LED housing; inspect for foreign material.
<b>2 Flashes</b>	Indicates that the unit is not enabled.	Verify configuration. Check the coin tube levels in the coin changer. Check the option switches in the coin changer. Note: Many machines disable the bill acceptor if the machine door is open and the door switch is not activated or if the machine is out of product.
<b>3 Flashes</b>	Indicates that the bill path needs cleaning for optimum performance.	Remove the magazine and LED housing and follow cleaning instructions (page 22) to clean the bill path.
<b>4 Flashes</b>	Indicates that something is obstructing the bill path.	Remove the LED housing and look at the bill path on the housing and inside the unit for foreign material; clean as necessary.
<b>5 Flashes</b>	Indicates that the magazine is removed (the unit will not accept without the magazine attached).	Reinstall the magazine.
<b>Continuous Slow</b>	Unit is defective.	Replace the unit.
<b>Continuous Fast</b>	The magazine is full of money.	Remove the money from the magazine.

# Connector Pinouts

1	2	3	4	5	6	7	8	9	10	11	12	13	14	15
16	17	18	19	20	21	22	23	24	25	26	27	28	29	30

	115 Volt AC Version	24 Volt AC/MDB Version
Pin 1	CREDIT RELAY, Common	*
Pin 2	MDB GROUND	CREDIT RELAY, NO
Pin 3	NEUTRAL ENABLE	24 VAC HOT
Pin 4	115VAC NEUTRAL (Power)	HOT ENABLE
Pin 5	NEUTRAL INHIBIT	KEY
Pin 6	KEY	MDB MASTER RECEIVE
Pin 7	\$1 CREDIT_NOT	*
Pin 8	INTERRUPT_NOT	*
Pin 9	\$5 CREDIT_NOT	*
Pin 10	GROUND	*
Pin 11	DATA_NOT	*
Pin 12	ESCROW, High	*
Pin 13	\$5 ENABLE, High	*
Pin 14	\$2 ENABLE, High/MDB COMMUNICATION COMMON	*
Pin 15	\$1 ENABLE, High	*
Pin 16	CREDIT RELAY, Normally Open	DC RETURN
Pin 17	MDB 34VDC	NEUTRAL INHIBIT
Pin 18	HOT ENABLE	NEUTRAL ENABLE
Pin 19	KEY	CASH COUNTER HI
Pin 20	115VAC HOT (Power)	24 VAC NEUTRAL
Pin 21	EARTH GROUND	KEY
Pin 22	OUT-OF-SERVICE_NOT	*
Pin 23	MDB MASTER RECEIVE	MDB 34 VDC
Pin 24	ACCEPT ENABLE_NOT	*
Pin 25	\$2 CREDIT_NOT/OUT OF SERVICE POWER	*
Pin 26	SEND_NOT	*
Pin 27	\$1 ENABLE, Low	*
Pin 28	\$2 ENABLE, Low/MDB MASTER TRANSMIT	*
Pin 29	\$5 ENABLE, Low	*
Pin 30	ESCROW, Low	*
* SAME AS 115 VAC VERSION		

## Mating Connector

30 Pin Header - AMP #2-87456-5 / Contacts - AMP #87756-6 / Key - AMP # 86286-1

---

## **Owner's Responsibility**

Upon request, owner must show proof of purchase when submitting equipment for service during the warranty period. Owner will assume all freight charges for shipment of equipment to an authorized service center while under warranty, and to *and* from the service center when outside the warranty period. Owner is responsible for out-of-warranty repair expenses, chargeable at prevailing rates set by authorized service centers or in effect at Mars Electronics service facilities. Complete written information must be supplied to the authorized service center for all items returned, including serial and model number, and a description of the malfunction.

## **Mars Electronics' Responsibility**

During the warranty period, Mars Electronics will repair or replace any parts which fail to function properly because of defects in material or workmanship. Mars Electronics shall not be liable for any consequential damages as a result of defects in material or workmanship.

Damage due to electrical overload, negligence, accidents, misuse, abuse, vandalism, or an act of God is not covered by Mars Electronics' warranty. Any alteration of the product after manufacture voids the warranty in its entirety.

The product to be repaired under warranty must be delivered to an authorized service center. Repairs or installation at the owner's location are not included in the warranty. During the warranty period, Mars Electronics will assume freight charges for return of the owner's equipment from the closest authorized service center via UPS or common carrier.

## **Service**

For service information, contact Mars Electronics or any Mars Electronics' authorized service center. Parts and labor that are Mars Electronics' responsibility will be provided without charge. Other service is at owner's expense. For service information, or the name of the authorized service center nearest you, write to:

Customer Services  
Mars Electronics  
1301 Wilson Drive  
West Chester, PA 19380  
1-800-345-8172