



MEI Cashflow SC83[®]

Installation & Operation Manual



2008[®]MEI Inc. All Rights Reserved.

The MEI device, MEI CASHFLOW, MEI EASITRAX and SODECO are registered trademarks of MEI in the U.S. and other countries. Information is subject to change without notice. MEI has made every effort to assure that the information in this document is accurate. However, we cannot be held responsible for any errors or omissions.



MEI UK International Ltd
Unit 51/52, Suttons Business Park
Suttons Park Avenue, Earley, Redding
RG6 1AZ, UK
Phone: +44 (0) 118 938 1100
Fax: +44 (0) 118 919 7878

EC Declaration of Conformity

Document Number: 20199-003110005-EC /G5

We, MEI, certify that the product described is in conformity with the following Directive(s):

89/336/EEC Electromagnetic Compatibility Directive (as amended)

73/23/EEC Low Voltage Directive (as amended)

2002/95/EC Restriction of Hazardous Substances Directive (as amended)

Description of product: *Cashflow SC83 Series Note Acceptors*

The product has been assessed by application of the following standards:

EN 55022	1998	Information Technology equipment-Radio disturbance characteristics-Limits and methods of measurement.
BS EN 55024	1998	Information Technology Equipment - Immunity characteristics - Limits and methods of measurement.
EN 60950-1	2001	Information Technology Equipment - Safety - Part 1:Generic requirements.
EN 60335-1	2002	Household and Similar electrical equipment appliances - Safety - Part1:General Requirements
EN60335-2-82	2003	Part 2-82: Particular requirements for amusement machines and personal service machines.

Signed.....

Title..... DIRECTOR

Dated..... JULY 2007

National and International
Standards Conformance

CashFlow® SC83 Series products operate at Safety Extra Low Voltage Level (SELV) as defined in EN60950 'Safety of Information Technology Equipment'. They may be designed into equipment complying with IEC950/EN60950 'Safety of Information Technology Equipment'.
CashFlow® SC83 Series products are of Class 2 construction.

Dangerous Environments

The CashFlow® SC83 Series must not be operated in the presence of flammable gasses, fumes or water.

Product Disposal

Do not dispose of any part of a CashFlow® SC83 Series by incineration.

Published by:

MEI

Unit 51 - 52 Suttons Business Park

Suttons Park Avenue, Earley, Redding

RG6 1AZ United Kingdom

Internet: <http://www.meigroup.com>

©MEI Inc. 2007

Except as permitted under the relevant local legislation, no part of this publication may be copied, transmitted, transcribed, or distributed in any form or by any means, or stored in a database retrieval system, or translated into any language (natural or computer), without the prior permission of MEI, Inc.
Copyright MEI Inc 2007.

©MEI Inc. 2007

MEI, Inc. is a registered trademark. MEI reserves the right to change the product, product specifications at any time. MEI has made every effort to ensure that the information in this document is accurate. MEI disclaims any liability for any direct or indirect losses (how so ever caused) arising out of use or reliance on this information.



When installing the SC83XX into a host machine, turn off all power.
When installing or removing the PROM observe all ESD precautions to prevent damage.

TABLE OF CONTENTS

OVERVIEW

Model Number	5
Serial Number	6
Features	8
Main Components of the SC83 Note Acceptor	9
Power Requirement	9

INSTALLATION AND REMOVAL OF COMPONENTS

Installing the Chassis	10
Inserting and Removing the Acceptor Module	11
Installing an Entry Guide	12
Installing the Cashbox	13
Removing the Cashbox	13
Installing Locks on the Cashbox	14

STS SUPPORT TOOL..... 15

UPDATING SOFTWARE

Cashflow Portable Programing Module (PPM)	16,17
Replacing the PROM	18-20

HARNESSING AND CONNECTORS

EBDS Interface Pin Out	21
RS232 Interface Pin Out	21

MAINTENANCE

Cleaning the Acceptor Module	22
Calibration	22

TROUBLESHOOTING

Diagnostic Codes	23
------------------------	----

Frequently Asked Questions24-27

SC83 DIMENSION DRAWING28

SCM DIMENSION DRAWING.....29

SCL DIMENSION DRAWING.....30

Product	Cassette Size	Bill Path Width	Family	Interface Option	Options	Description
SC						CASHFLOW SC

(none)	600-note cassette
M	900-note cassette
L	1,200-note cassette
N	No cashbox

66	66mm bill path (US)
76	76mm bill path (Canada)
83	83mm bill path (Intl)
85	85mm bill path (UK)

0	Gaming downstacker
1	Gaming upstacker
2	Retail

1	RS-485
2	Netplex IGT specific
4	Optically isolated EBDS
7	RS-232
8	USB

A	SPC USB triport
B	BNF
E	EASITRAX Soft Count
G	GDS USB
N	No cashbox
P	Prom
R	Retail kit
RL	Retail kit w/ cassette lock
U	IGT USB
W	EBDS/SPC USB (tri-port)
X	Deep cashbox
Y	EBDS/GSA USB (tri-port)

Serial Number

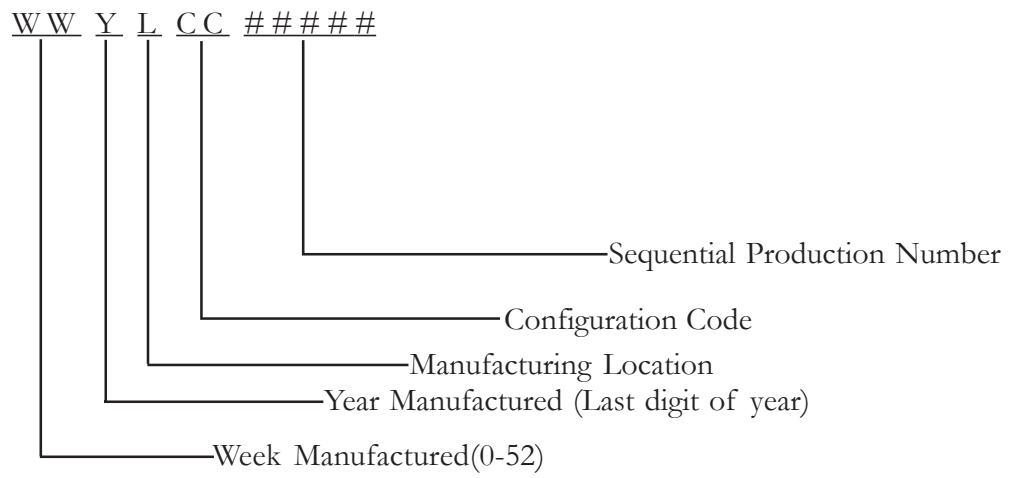

OVERVIEW

COMPONENTS

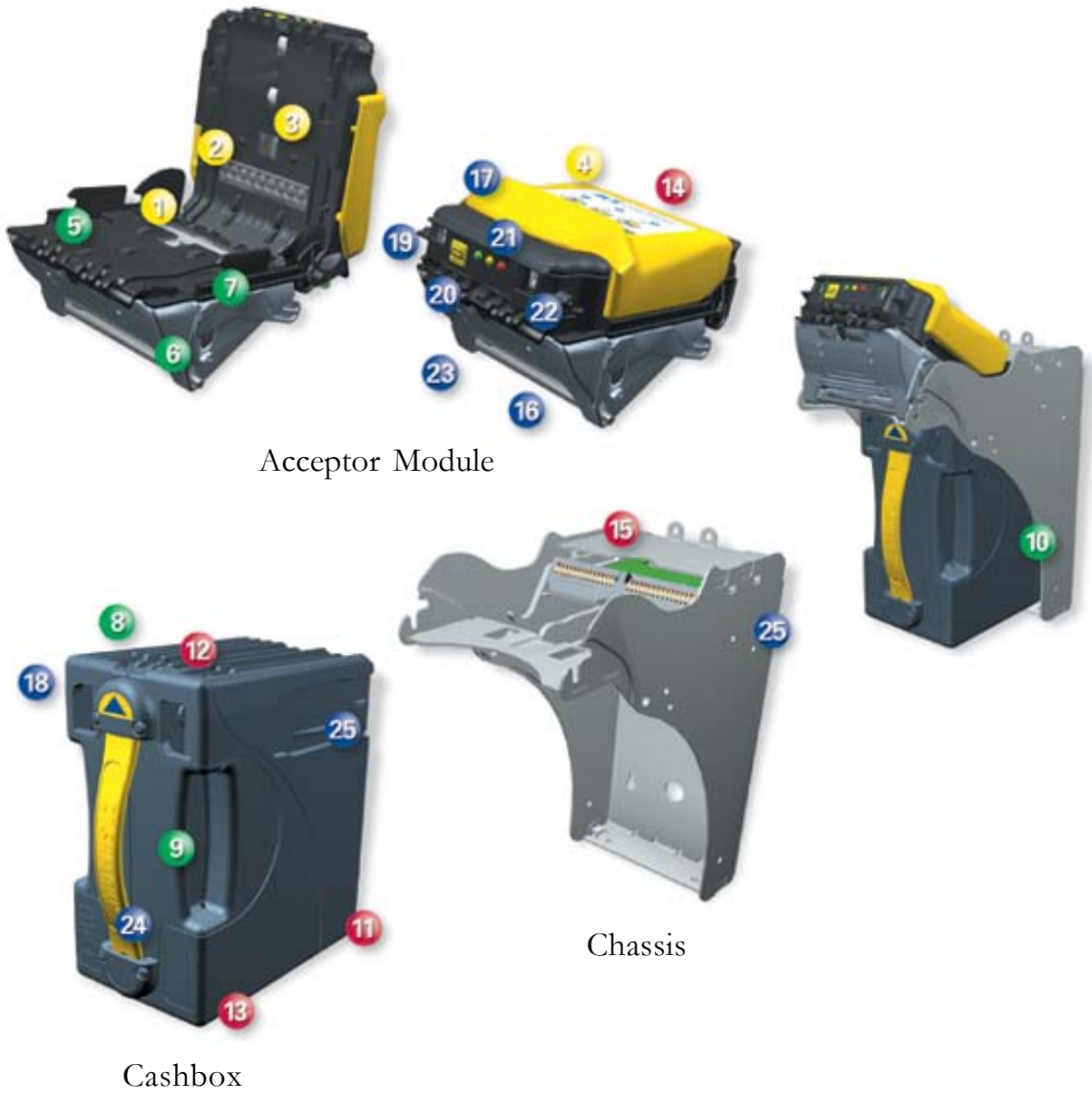

OVERVIEW

Features

- 1 LIGHT BAR
- 2 LENSED RECEIVER
- 3 CUSTOM BAR-CODE READER
- 4 100 MHZ DSP PROCESSOR
- 5 EARLY NOTE PICK-UP
- 6 SMOOTH SEALED NOTE PATH
- 7 DIRECT ROLLER DRIVE
- 8 RIDGES MATE WITH ACCEPTOR
- 9 INTERNAL DIRECT ROLLER DRIVE ELEVATOR
- 10 SHORT NOTE PATH
- 11 DURABLE WELDED PLASTIC EXTERIOR
- 12 RECESSED PLASTIC GEARS
- 13 DUAL LOCK CAPABILITY
- 14 COMMON ACCEPTOR MODULES
- 15 PC STYLE EDGE CONNECTOR INTERFACE CARDS
- 16 ACCEPTOR RELEASE LATCH
- 17 NOTE PATH RELEASE
- 18 DISPUTE RESOLUTION WINDOW
- 19 ENTRY GUIDE & POWER MOUNTING
- 20 CONFIGURATION BUTTON - NOT USED ON SC83 SERIES
- 21 DIAGNOSTIC LEDS - SEE PAGE 22 FOR DETAILS
- 22 USB SERVICE PORT - SEE PAGE 15 AND FIGURE 2 FOR DETAILS.
- 23 ACCEPTOR USER INTERFACE
- 24 FLEXIBLE HANDLE
- 25 PASSIVE CASHBOX LATCHES

OVERVIEW

Main Components of the CASHFLOW SC83® Bill Acceptor

The CASHFLOW SC83® consists of three main components



Cashbox/LRC



Acceptor Module

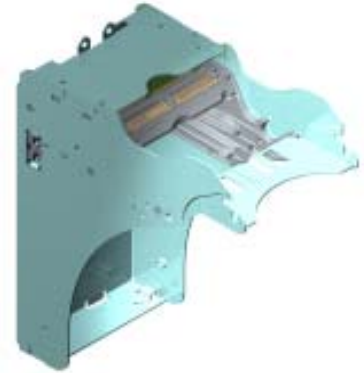

Chassis

The Acceptor Module and Cashbox are interchangeable with other identical SC83 models.

Bill Entry Guides for the CASHFLOW SC83®

Not all bill entry guides fit in every machine. Your choice regarding bill entry guides will depend on machine specifications. Below are two bill entry guides that we currently manufacture. For customers who prefer to tool their own bill entry guide, please contact our technical department.



Platform Bill Entry Guide



Universal Bill Entry Guide

Power Requirements

Standby:	10 Watts
Acceptance:	Peak 30 Watts
Stacking: Peak:	70 Watts
Input Voltage:	+12-28 VDC

INSTALLATION

Note: Always power down machine prior to Installation.

The cashbox does not lock to the chassis. When you remove the unit from the container or when the unit is not installed in the machine, you must never carry the bill acceptor by the handle of the cashbox. The cashbox may release causing the rest of the unit to fall and damage the chassis.

Installing The Chassis

- Most models have a configuration-specific cable installed on the back of the chassis (see Interface Manual 002850103 for more details). Connect the cable from the chassis to the machine. Always dress all wires to avoid interference with any equipment operation.

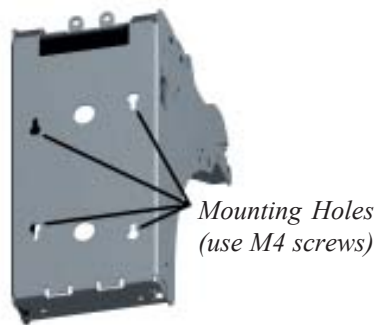
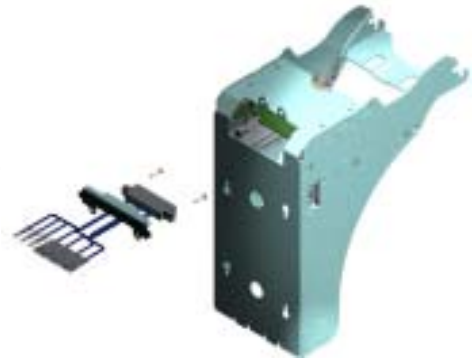

Back

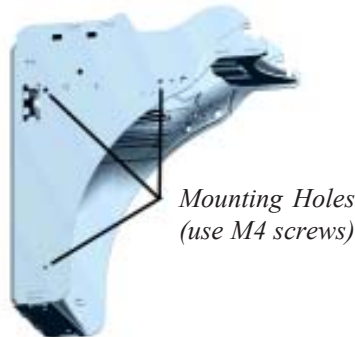

Side

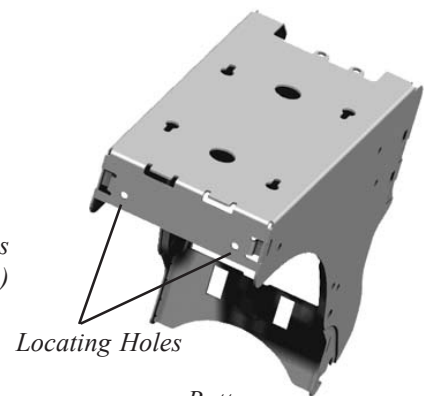

Bottom

Note: If you have a custom configuration, you may need to contact our technical support group for assistance.

- Once the connections are made, you will need to line up the locating holes on the bottom of the chassis with the machine's locating pins. Line up the mounting screw holes and insert M4 screws through several of the 10 mounting holes. There are three on each side of the chassis and four located on the back. Leave screws slightly loose until the bezel is mounted and aligned with the machine door closed. Screws must not exceed a 6mm depth through the mounting plate, otherwise they may interfere with the removable cashbox.

Earth Grounding Considerations:

Use star washers when mounting the chassis via the rear mounting holes to ensure the chassis has a good electrical connection to the machine's mounting plate. When using the side mounting holes ensure the lower (upper if Up Stacker) mounting hole is used.

INSTALLATION

Inserting and Removing the Acceptor Module

- Insert the Acceptor Module so that the release lever locks into place. The acceptor should be firmly seated to ensure proper engagement of the locking feature.
- To remove the unit, pull upwards on the release lever located on the front of the Acceptor Module and pull away from the chassis.

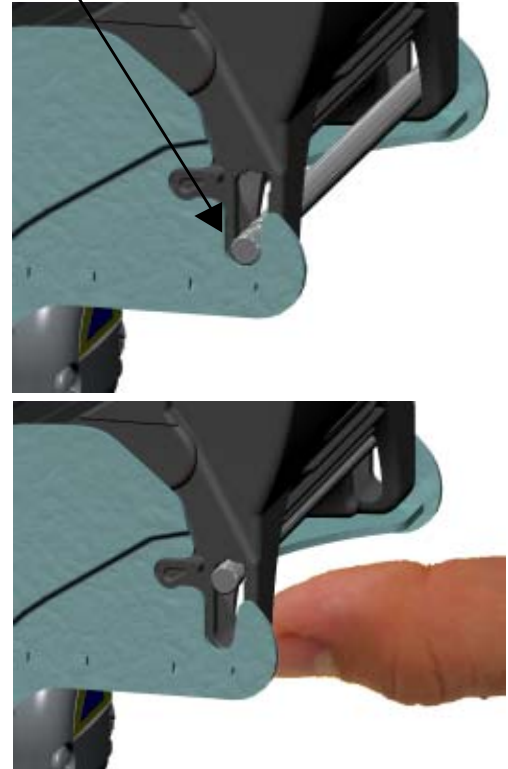
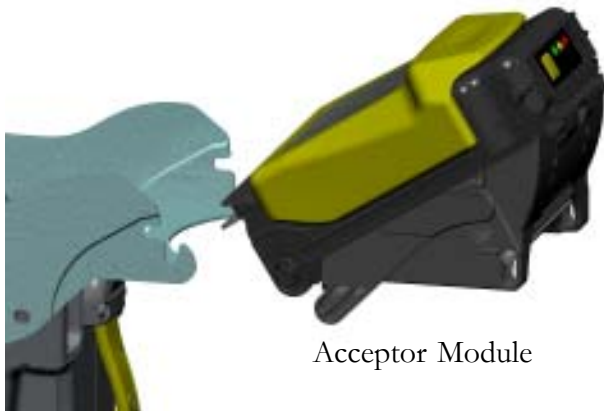

INSTALLATION

Installing A Bill Entry Guide

- To install a bill entry guide, just slide it onto the Acceptor Module until it locks into place. No screws are required. If the bill entry guide has lights, you will have to first connect the harness from the bill entry guide to the eight pin connector located on the left hand side of the face of the Acceptor Module.
- Make sure that the bill entry guide is aligned so the machine door closes properly.

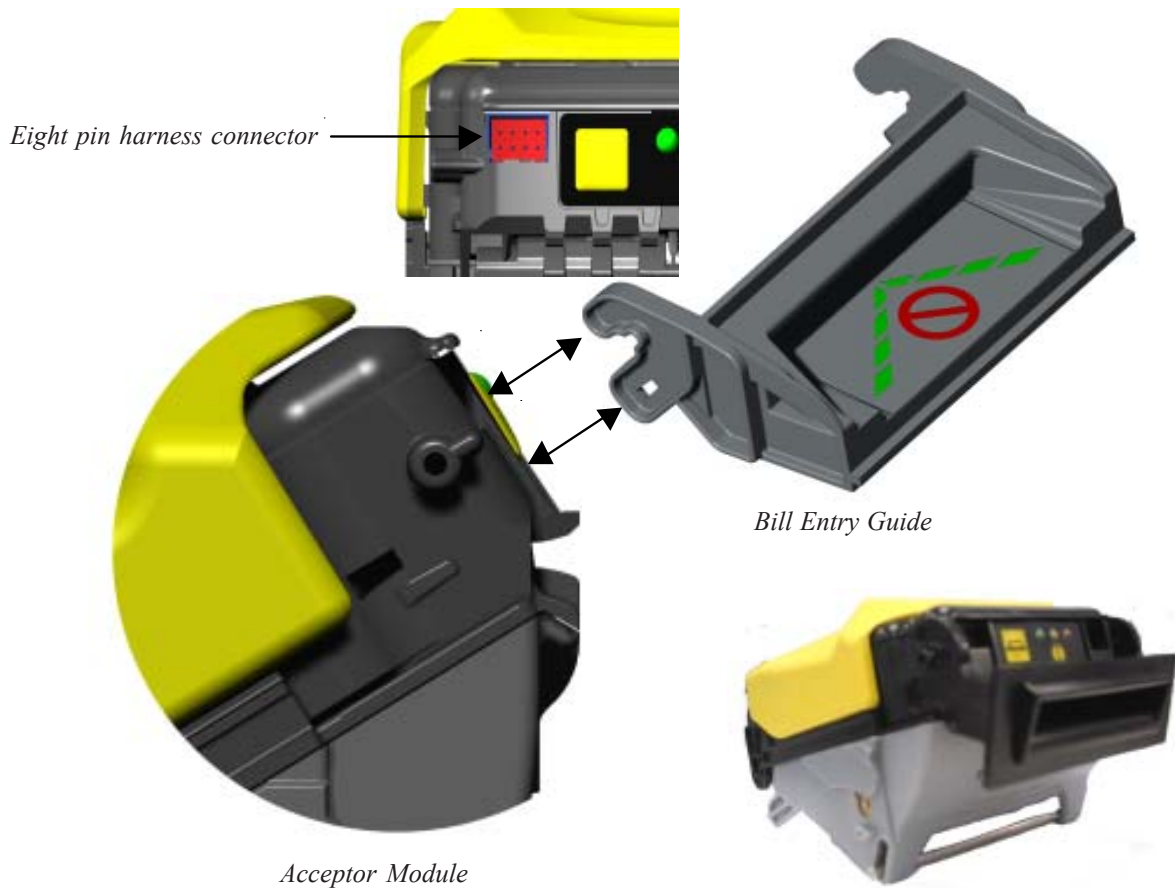

- Once the bill entry guide is aligned properly, remember to go back and tighten the screws on the chassis (refer back to Chassis installation instructions).
- To remove a bill entry guide, slide a flat head screwdriver between the bill entry guide and the acceptor module. (as shown in the diagram on the right)



INSTALLATION

Installing the Cashbox

- With the chassis mounted securely to the machine, you may now insert the cashbox into the chassis. The cashbox has slots on both sides that will guide it into the chassis. When you insert the cashbox, you will feel some resistance from the two springs inside the chassis. Make sure to insert the cashbox all the way in so that the rear of the cashbox is flush against the chassis wall.



Removing the Cashbox

- When the note acceptor is installed in a machine, you just need to grab the yellow strap on the cashbox and pull firmly to release it. The cashbox does not lock on to the chassis.

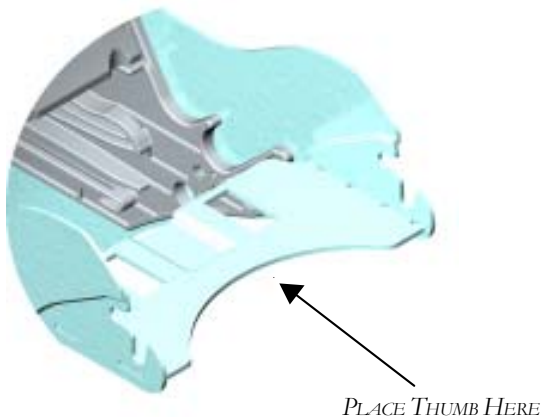

- To remove the cashbox when the unit is not installed, grab on to the yellow handle and place your thumb on the chassis where indicated in this diagram. Placing your thumb at this location will give you sufficient leverage to remove the cashbox.

INSTALLATION

Installing Locks on the Cashbox

The cashbox may be fitted with either one or two security locks. The product is designed to accept locks from a range of manufacturers including: -

Medeco
Kaba
Abloy
VSR
Miwa
Duo
ILCO

Standard 5/8" and 1-1/8" formats are supported. There is a significant variety of lock designs, and spacer washers may be required for some lock types. Locking hasps are shipped with every cashbox. Contact MEI for cashbox lock specifications.

Locks vary greatly in price, security, keying policies, etc. The customer is responsible for selecting a lock with performance that is fit for the intended purpose. MEI does not test or endorse any specific brand of lock for security characteristics. For applications requiring NO locks, a non-secure "slam" latch is available: MEI Part Number 252260001P1/P12 NLC CASHBOX LATCH.

When only one lock is used, the remaining blank hole does not give access to the contents of the cashbox. However, some jurisdictions may require a blanking plug. Contact MEI for assistance in obtaining a suitable plug.

When two locks are installed, they must rotate in opposite directions. See the figure below.

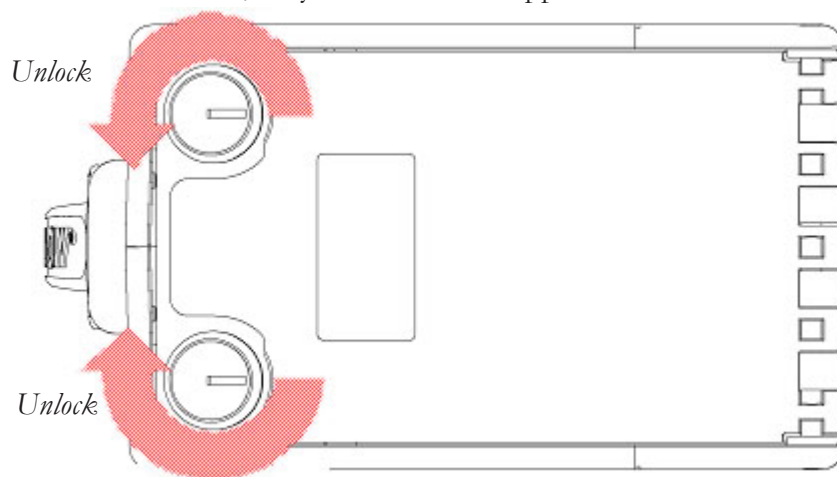

Bottom View of Cashbox

STS SUPPORT TOOL

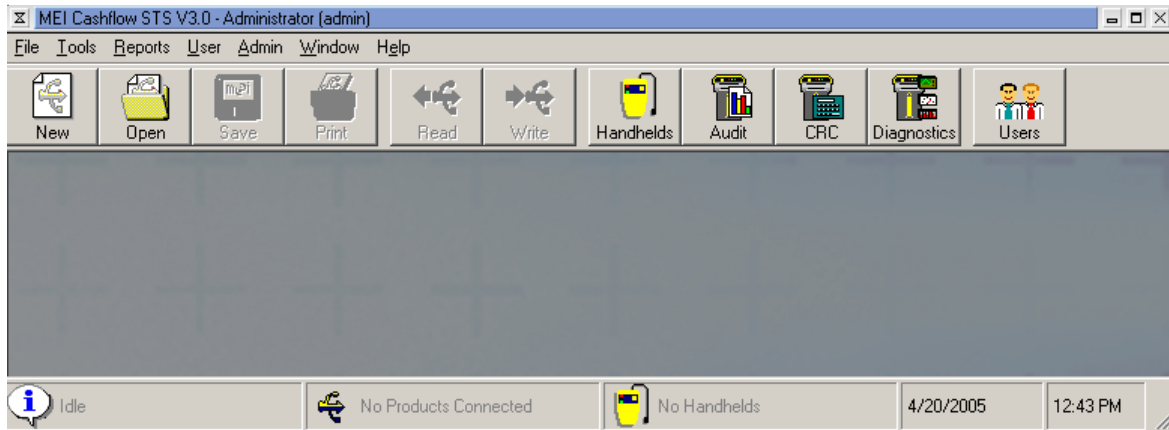

STS Support Tool is software that is installed on your computer for use with the CASHFLOW SC83[®] Bill Acceptor. This software, together with the Portable Programming Module (PPM) handheld device supports the Bill Acceptor both in the field and the workshop.

The enabled functions will depend on the type of license given to you, but may include:



1) Handhelds – allows you to manage Handheld Devices, downloading files for Bill Acceptors, changing Audit settings and upgrading of Handheld firmware.



2) Configuration – allows you to load and save configuration to or from a file, and also a connected Bill Acceptor or Handheld device. This configuration includes Bill Acceptor Bootloader and Application Firmware, as well as basic Bill Acceptor and Bill Settings.



3) Audit – allows you to view stored, and retrieve new audit data from Bill Acceptor devices. Handhelds will automatically save retrieved audits to the database on connection.



4) CRC – allows you to perform CRC checks on a connected Bill Acceptor device.



5) Diagnostics – allows you to perform scripted or self-tests on a connected Bill Acceptor.

More Detail information on this tool is offered in the STS User Manual. For additional information on this tool please contact your MEI representative.

UPDATING SOFTWARE

There are two ways of updating the software of a Cashflow SC83® note acceptor.*

- 1) Via a hand held device called the Cashflow® Portable Programming Module (PPM).
- 2) By replacing the programmed PROM (Chip Change).*

Portable Programming Module

Connecting the PPM to the CASHFLOW SC83®

1. Locate the two USB ports located on the top of the Portable Programming Module (See fig. 1 below).
2. Plug the type A end of your USB harness to the USB type A port of the **PPM**. Plug the type B end of the same USB harness into the USB type B port of the Cashflow SC83®. (see fig.2).

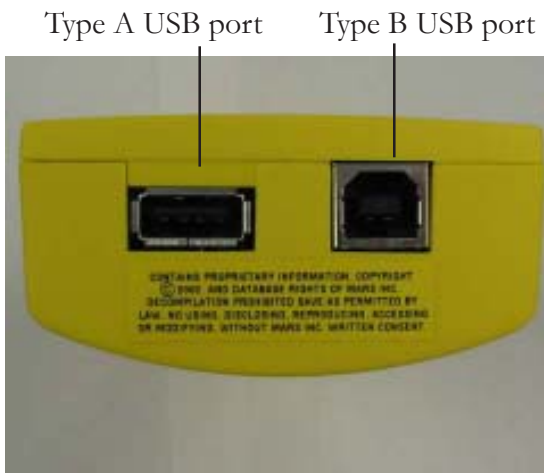

fig.1 (CPM)



fig.2

****Note: Once a PROM (chip) is installed, the note acceptor can no longer be programmed via the programming module (PPM). Installation of a PROM will disable the ability of the programming module (PPM) to communicate with the note acceptor. Future software changes can only be made by replacing the PROM (chip change).***

UPDATING SOFTWARE

CPM Downloading Procedure

1. After connecting the PPM to the Cashflow SC83® via the USB interface (refer to previous page illustration), you are now ready to start the download procedure.
2. Press the square download button located on the front of the PPM. (see fig.2 on previous page)
3. When downloading, the PPM will have a solid green and a flashing red LED, indicating the PPM is busy. Once the download is complete, the LED on the PPM will change to solid green and a solid red, indicating a successful download. The note acceptor will perform a run and stack and the the LEDs on the PPM will turn off.
4. Disconnect the USB harness from the Cashflow SC83® once the LEDs on the PPM are off.
5. Once download is complete, the Cashflow SC83®'s diagnostic LEDs will flash five times green continuously until communication between the note acceptor and the machine is re-established.

Diagnostic Codes For The PPM

Led Codes:	solid green	= PPM on
	solid green + flashing red	= PPM busy
	solid green + solid red	= upgrade complete
Error Codes:	flashing green	= battery low
	alternating flashing green and red	= wrong product connected
	solid green + flashing red 1 time	= notes reader error
	solid green + flashing red 2 times	= PPM error
	solid green + flashing red 3 times	= program error

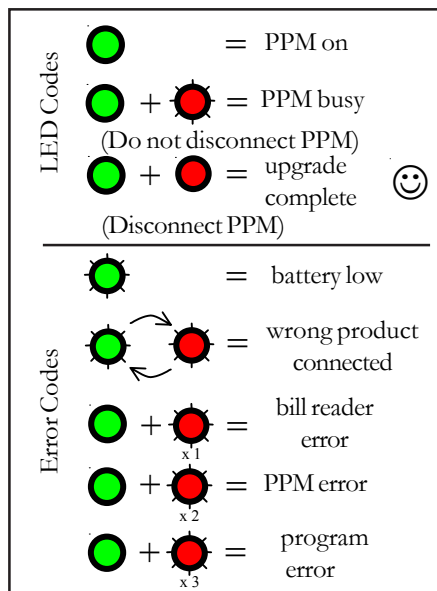

UPDATING SOFTWARE

Replacing the programmed PROM (Chip Change)

This is not necessary for all applications, but only those that occur in jurisdictions requiring PROM to be installed.

Note: As soon as even one PROM has been installed into an acceptor module, the acceptor module will not be able to be re-programmed with a PPM. To re-program an acceptor module that has had a PROM installed, you **MUST** change or insert a new PROM (perform a chip change). When power is re-applied, the Acceptor module will be re-programmed from the PROM.

1. Remove the acceptor module from the chassis. (Instructions on how to remove it are on page 10).
2. Open the acceptor module by placing the palm of your hand on the front of the module and placing your fingers around the top of the yellow cover as shown in the diagram below. Pull the cover toward your hand and then lift up, opening the module head fully.



3. Remove the yellow cover from the acceptor module by turning the acceptor module so that the top of the cover is facing you. Wedge the tips of your fingers underneath the left and right front top corners of the yellow cover. Lift the cover's corners out and then back toward you to release the cover. The cover will be released once the cover has cleared the black ramps as shown in the diagram below.



4. Once the yellow cover is released in the front, slide it back and remove it.

UPDATING SOFTWARE

Replacing the programmed PROM (Continued).

5. You may now remove the PROM using a PLC puller.

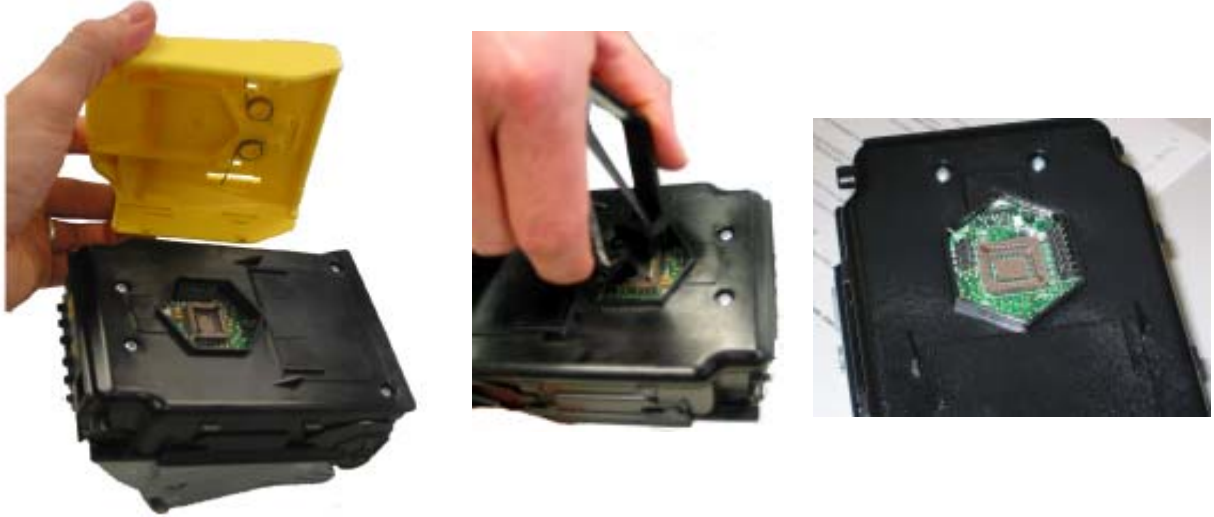

6. Insert the new PROM.

Replacing the yellow cover

Note: To install the yellow cover, the acceptor module must remain open.

7. To re-install the yellow cover, align the cover back to the position shown below.

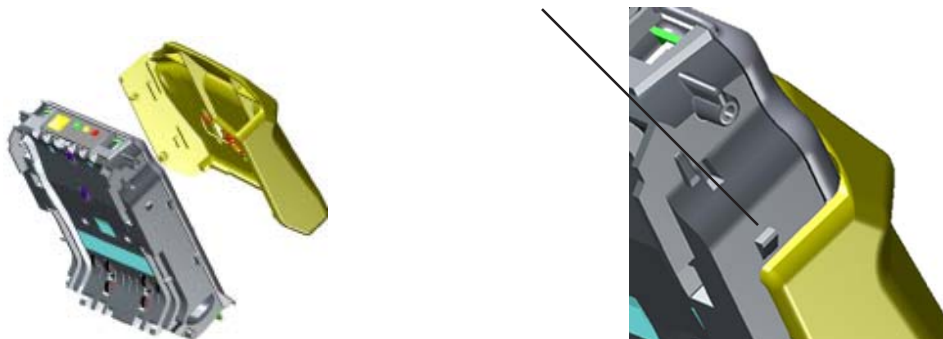

UPDATING SOFTWARE

Replacing the programmed PROM (Continued).

8. Once in position, move the yellow cover forward (as if you were opening the acceptor module) until the cover locks into place.



9. Close the acceptor module and re-install it into the chassis.

10. If the power is on, the unit will power up and perform a run and stack.

HARNESSING AND CONNECTORS

EBDS Interface Pin Out

Note: Some Cashflow SC83® units will come with connectors that are “OEM-Specific.” Please refer to the host machine manual for pinout and connector information.

Cashflow SC83® note acceptors with an EBDS Interface will have a harness with a 12-pin connector.

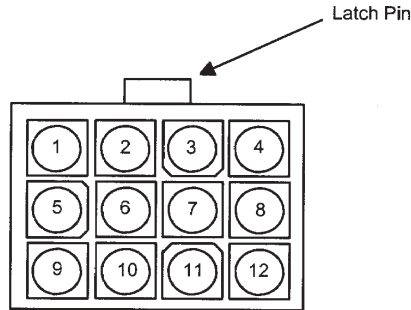

12-Pin Chassis Docking Station Connector (End View)

SC8307 RS232 EBDS version

Connector Pin #	Wire Color	Signal	P2 pin
1	White	External Inhibit	10
2	Gray	Bezel LED drive	12
3	Not Populated	_____	_____
4	Yellow	Out of Service	11
5	Blue	Ground ²	2
6	Pink	RS232 EBDS RXD ¹	L
7	Blue	Power - ²	B
8	Purple	LED Supply	9
9	Not Populated	_____	_____
10	Not Populated	_____	_____
11	Green	Power +	1 & A
12	Tan	RS232 EBDS TXD ¹	K

NOTES: ¹ RXD refers to input to the note acceptor. TXD is an output.

² Pins 7 and 5 are tied with a loop of wire in back of the 12-pin connector.

SC8304 Opto Isolated EBDS version

Connector Pin #	Wire Color	Signal	P2 pin
1	White	Aux A	14
2	Gray	LED -	12
3	Red	V opt	7
4	Yellow	V ret	3
5	Blue	Ground ²	2 & B
6	Pink	Isolated Reset	6
7	Black	Aux B	15
8	Purple	LED +	8
9	Brown	Isolated TXD ¹	4
10	Orange	Isolated RXD ¹	5
11	Green	Power +	1 & A
12	Not Populated	_____	_____

NOTES: ¹ RXD refers to input to the note acceptor. TXD is an output.

² Pins 12 and 5 are tied with a loop of wire in back of the 12-pin connector.

Non Committed Contacts

Depending on the desired interface, the Cashflow SC83® may be supplied with one or two sets of non committed contact leads for OEM use. The contacts are rated at 125VAC, 5AMPS Maximum.

Wire connections are as follows:

Black	OEM SW1 or 2 , COM
White	OEM SW1 or 2 , NC
Red	OEM SW1 or 2 , NO

Maintenance

Periodic maintenance can improve the performance and extend the working life of a note acceptor. Additional attention may be required if the note acceptor becomes inoperable due to a jammed object or acceptance rates fall below normal.

Cleaning the Acceptor Module

Note: You must remove the acceptor module from the chassis to open the front sensor area. Forcing the note path open without removing the acceptor module from the chassis will damage the unit. Remember to turn off the machine (as per machine manufacturer) when performing any cleaning.

- Remove the acceptor module from the chassis. (Instructions on how to remove it are on page 10).
- Open the acceptor module by placing the palm of your hand on the front of the module and placing your fingers around the top of the yellow cover as shown in the diagram to the right. Pull the cover toward your hand and then lift up, opening the module head fully.
- Clear the note path area of any foreign objects.
- Wipe the note path and sensor areas as needed with a soft damp cloth. For stubborn dirt, a small amount of mild non-abrasive soap may be added to the water before dampening the cloth. Make sure no streaks or residual soap remain on the note path.





Note: Cashflow SC83® does not require the use of a cleaning card. Never use a petroleum-based product to clean this device! Petroleum based products will damage the note path. Mild non-abrasive soap is preferred over alcohol.

Calibration























The Cashflow SC83® series note acceptor was designed not to require calibration. Thus, the unit has no switch settings or calibration mode that allows a user to perform a calibration. Calibration may only be performed by MEI trained technicians.

TROUBLESHOOTING











Diagnostic Codes

-  Red conditions - Hard Fault. One of the note acceptor components needs to be replaced.
-  Yellow conditions - Soft Fault. The operator can correct the issue at the machine.
-  Green conditions - No Fault. No problem with the note acceptor.

   Solid Light    Flashing Light

LED Indicators	Status	You Need to
Solid Green 	Normal	Take no action
1 Flash Green 	Disabled by machine interface	Fix the machine condition (e.g. fill the coin hopper)
2 Flash Green  	Disabled by network interface (if applicable)	Correct the network condition
Solid Yellow 	Cashbox not seated or not present	Re-seat the cashbox
1 Flash Yellow 	Poor acceptance	Clean the acceptor
2 Flash Yellow  	Jam in acceptor	Clear the jam from the acceptor
3 Flash Yellow   	Jam in cashbox	Remove the acceptor and try to clear jam
Solid Red 	Cashbox full	Replace with an empty cashbox
1 Flash Red 	Acceptor fault	Replace the acceptor with a programmed spare
2 Flash Red  	Interface board hardware fault	Replace the interface board
3 Flash Red   	Invalid Config. Coupon	Edit or Refill another Coupon
Green-Yellow-Red Solid Lights   	Hardware fault	Re-program or Replace Interface Card
Green and Red Flashing  	In Calibration Mode	Insert Calibration/ Test Coupon

EASITRAX® SC DIAGNOSTIC CODES

4 Flash Red 	Asset # mismatch	Insert cashbox w/ blank or matching asset # in RF tag
5 Flash Red 	Acceptor fault	Insert cashbox with a RF tag
6 Flash Red 	Communications error	Reseat cashbox or replace w/ cashbox w/ another RF tag
7 Flash Red 	Asset # not found	Enter Asset # into Acceptor head using STS Software
Green-Yellow-Red   	Checking tag Status/	Wait 5 seconds to determine tag
All Solid / All Flash   	Antenna PCB not Found	status/Replace Antenna PCB

Note: By opening the machine door, you will disable the primary interface. The 10-second delay allows you to see a normal condition on the unit prior to the MMI display update.

FREQUENTLY ASKED QUESTIONS

- 1) What are the 3 parts that make up a CASHFLOW SC83® unit?

A CASHFLOW SC83® unit consists of an acceptor module, chassis and cashbox. For more information on these modules refer to page 8 of the CASHFLOW SC83® Installation & Operation Manual.

- 2) What purpose do the Cashbox arrows serve?

Arrows highlight a cashbox's position (upright or upside-down). Arrows provide a visual aid to crews who frequently arrange cashboxes by position to signal that they are full or empty.

- 3) What is the purpose of the USB and 8-pin connectors on the front of the Acceptor Module?

The USB connector is used to connect a PPM (Portable Programming Module) to a CASHFLOW SC83® unit. The PPM is used to download new software into a CASHFLOW SC83®. The purpose of the 8-pin connector is to provide appropriate drive voltage and enable signals in some lighted entry guides that get installed on the note acceptor. Some entry guides do not plug into the note acceptor, they plug directly to the host machine.

- 4) How is software updated in CASHFLOW SC83® Flash units and PROM units in the field?

Flash versions of CASHFLOW SC83® units can be updated in the field by using a PPM (Portable Programming Module). PROM versions of CASHFLOW SC83® units can be updated by replacing the PROM Chip that is located under the yellow acceptor latch on the acceptor.

- 5) What is a PPM (Cashflow Portable Programming Module) and how does it work?

A PPM is a yellow handheld device that is programmed by MEI and is used to download software into a CASHFLOW SC83® Flash units. The PPM consists of a yellow button, a red and green LED and 2 USB connectors. To use a PPM, first connect a USB harness to the front of a CASHFLOW SC83® unit then connect the other end to the PPM. Then press the yellow button and the PPM downloads new software into the CASHFLOW SC83® unit. The PPM uses the red and green LEDs to report its status and also gives error messages. For more information on the PPM refer to the PPM User Guide.

FREQUENTLY ASKED QUESTIONS

- 6) Can a PPM be used to update software for PROM CASHFLOW SC83® units?

No. A PPM can only be used to download software into Flash CASHFLOW SC83® units.

- 7) How can I tell the difference between a Flash and PROM CASHFLOW SC83® unit?

There are two ways to determine the difference:

- 1) The STS Program can be used to determine if a unit is a PROM or Flash.
- 2) You can remove the yellow cover on the acceptor. If a PROM is in the socket, it is a PROM unit. If no PROM is present, it is a Flash unit (Refer to pages 17 thru 19 on PROM units).

- 8) What are the MMI Diagnostic Error Codes (Green, Yellow and Red LED)?

Please refer to page 22 of this operation and maintenance manual for the MMI Diagnostic Error Codes.

- 9) Can a CASHFLOW SC83® unit be calibrated in the Field?

A CASHFLOW SC83® unit can not be calibrated in the field. The CASHFLOW SC83® is designed not to require field calibration. Calibration is only required after certain repairs that are done to a CASHFLOW SC83® unit. Therefore, only an approved CASHFLOW SC83® Service Center are trained to calibrate a CASHFLOW SC83® unit.

- 10) What are the differences among model #'s?

SC6602 is a Flash unit made to interface to IGT's Netplex/SPC machines. It uses the IGT ID024 interface and SPC USB interface.

SC6604 is a Flash unit made to interface to various machines. It uses MEI Opto Isolated EBDS Interface.

SC6607 is a Flash unit made to interface to various machines. It uses MEI RS-232 EBDS Interfaces.

- 11) What are the differences among interfaces?

MEI EBDS (Extended Bi-Directional Serial) Protocol is a proprietary MEI protocol specification used to accomplish two-way serial communication between the bill acceptor and a host machine. It is not used for interfacing to IGT machines. Open collector EBDS uses opto isolated interface hardware. RS-232 EBDS uses RS-232 level interface hardware.

IGT Netplex (Serial) Protocol is proprietary IGT interface used to communicate between the IGT host machine and the Bill Acceptor.

IGT SPC (USB) Protocol is proprietary IGT interface used to communicate between the IGT host machine and the Bill Acceptor.

FREQUENTLY ASKED QUESTIONS

12) How is a CASHFLOW SC83® unit manufacturing date determined?

Locate the unit's serial number on the product label. The product label is located on the front of the acceptor module below the entry guide.

The first three digits of the serial number are the date code of the note acceptor. The first two digits indicate the week of the year it was made. The third digit indicates the year of manufacture.

For example: 082 means the unit was manufactured the 8th week of 2002.

13) How and how often should I clean the CASHFLOW SC83® unit?

The best way to clean a note acceptor is with mild, non-abrasive, diluted cleaning solution sprayed onto a soft cloth and not directly onto the note acceptor. Remove the acceptor and open the note acceptor's mouth. Wipe out the note path. Cleaning should be performed after two years, depending upon use, or if the unit's acceptance rate drops below normal.

14) Can I use alcohol to clean a CASHFLOW SC83® unit?

Alcohol is not the preferred cleaning solution (Refer to Question # 13.).

15) Can I use cleaning cards?

Not necessary! Cleaning cards offer simple preventative maintenance for some note acceptors. Since the CASHFLOW SC83® unit is easily opened, more effective cleaning can be accomplished with a soft, lint-free cloth and an appropriate cleaning solution. (Refer to Question # 13.)

16) What is the operating voltage for a CASHFLOW SC83® unit?

The operating voltage range is +12 to +28 VDC.

17) Does a CASHFLOW SC83® unit have dip switches?

A CASHFLOW SC83® unit does not have any dip switches. Notes can be enabled and disabled by using a configuration coupon. Contact MEI for more information.

18) What is the purpose of the red, black and white wires that come out of the main harness?

The wires are connected to an internally mounted switch and are used in conjunction with Player Tracking Systems to identify that a cashbox is present or that it has been pulled. Different combinations allow normally open or normally closed wiring.

FREQUENTLY ASKED QUESTIONS

19) How do I clear a note jam?

Remove the acceptor by pulling upwards on the release lever located on the front of the acceptor module and pull away from the chassis. Open the acceptor by sliding the yellow acceptor latch forward then clear the note jam.

20) Is it OK to swap Acceptors among my machines?

Same model Acceptors may be easily swapped (i.e. SC8302 to another SC8302). Verify that the following has been confirmed by the STS program **before installing back into the machine and applying power:**

- 1)The correct firmware is installed.
- 2)The correct BEG is installed for that particular machine.
- 3)The correct acceptor configurations are selected.(bills are enabled/disabled, proper BEG selected)

Different model acceptors (i.e. SC8304/07 to an SC8302 or vice versa) require, in addition to the changes above, a matching interface card (PCB).
SC8304/07 require EBDS interface card (PCB).
SC8302 require netplex interface card (PCB).

21) Who can I contact for service on a CASHFLOW™ SC83?

Visit our website at www.meigroup.com for a list of service centers that repair the CASHFLOW SC83® .

DRAWINGS

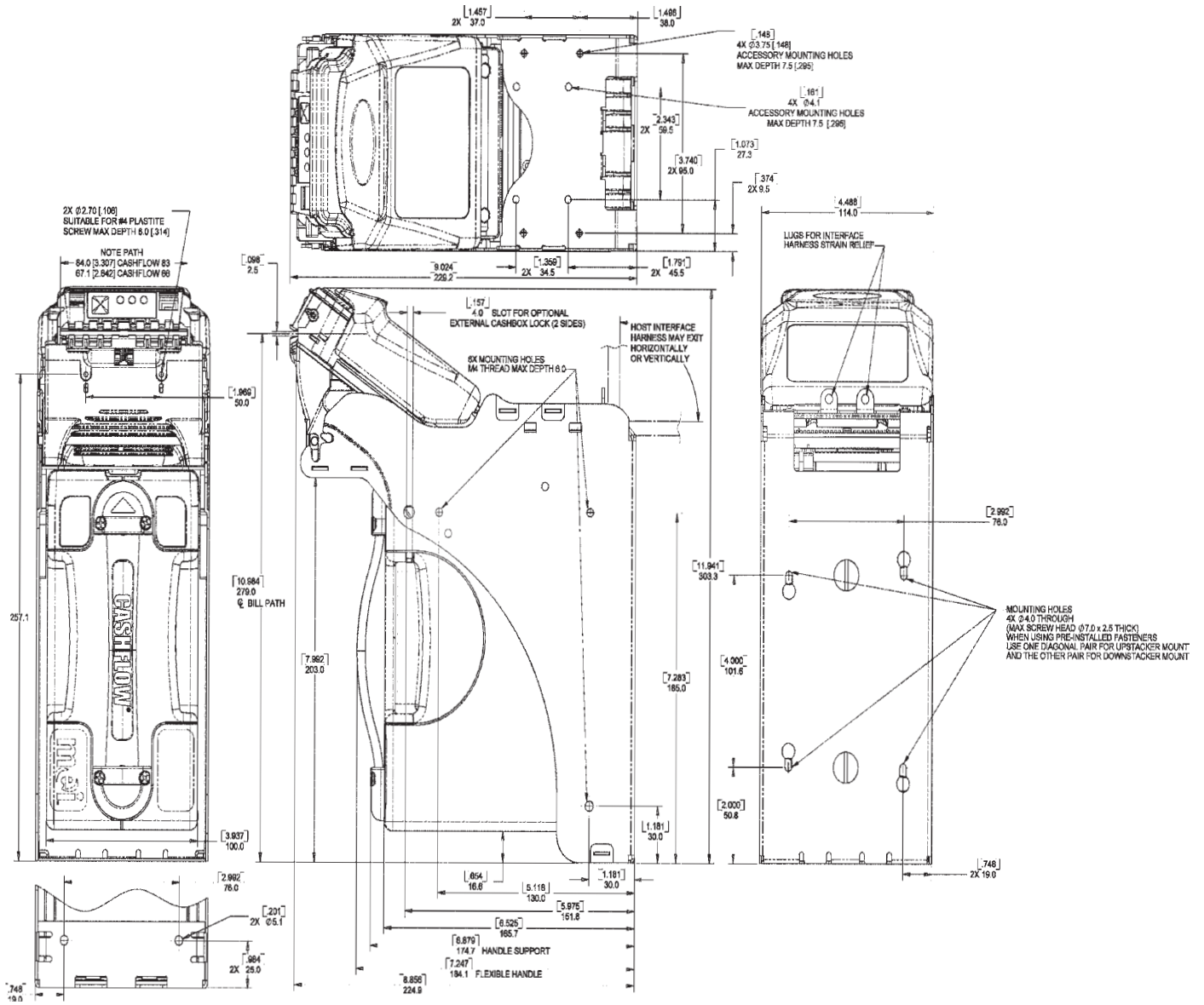

NOTES:

- 1.) DIMENSION UNITS ARE (INCH) / (MM) IN CASE OF ROUNDING ERRORS MILLIMETER DIMENSIONS ARE PRIMARY INCH VALUES ARE FOR REFERENCE ONLY.
- 2.) SEE DRAWING 252055023 FOR BILL ENTRY GUIDE DESIGN AND MOUNTING.
- 3.) SEE DRAWING 252050011 FOR CASSETTE LOCK SPECIFICATIONS.
- 4.) FLEXIBLE HANDLE AND HANDLE SUPPORTS MAY BE REMOVED IN APPLICATIONS WHERE SPACE IS RESTRICTED.
- 5.) REFERENCE DIMENSIONS SHOWN WITH ().

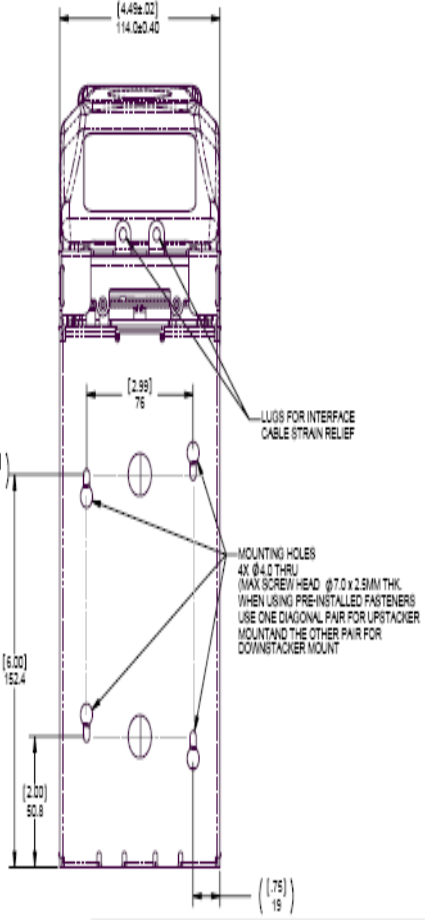
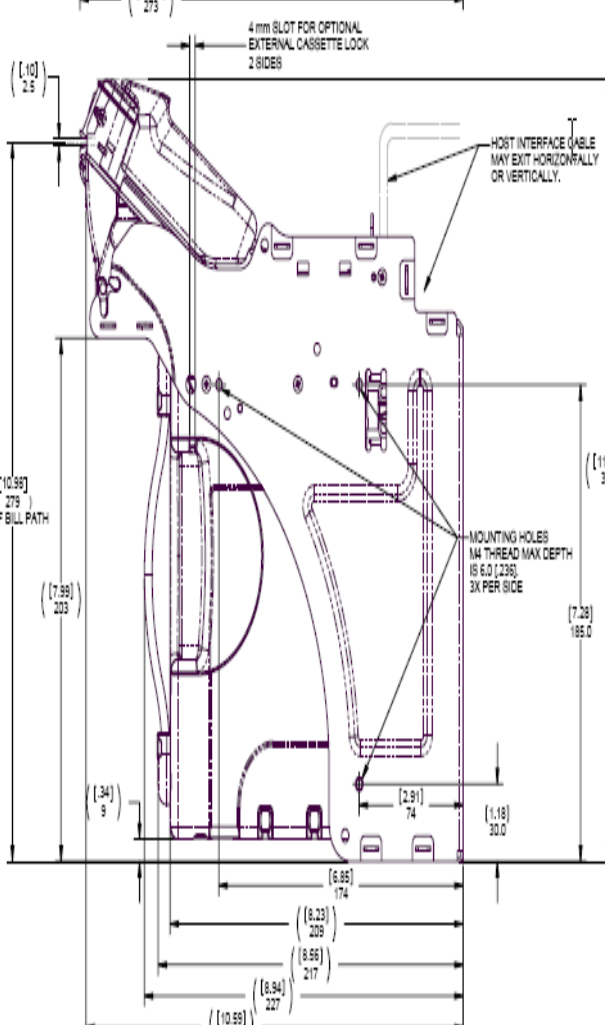
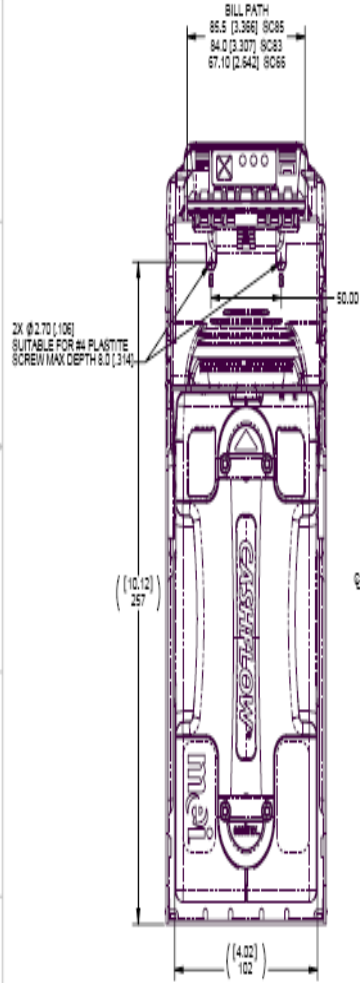
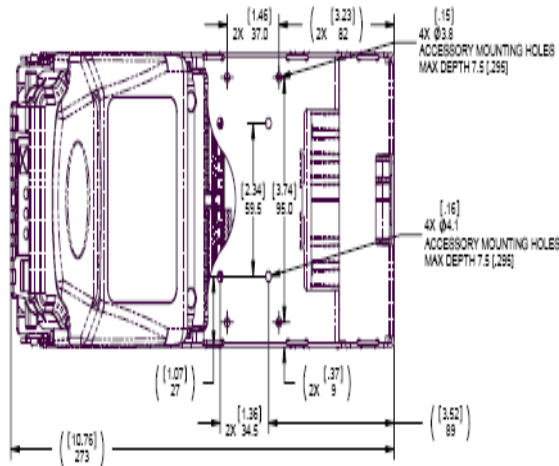

NOTICE OF CONFIDENTIALITY: THIS DOCUMENT AND THE INFORMATION CONTAINED IN IT ARE CONFIDENTIAL AND ARE THE PROPERTY OF MEI. THEY MAY NOT BE IN ANY WAY REPRODUCED, COPIED, OR DISCLOSED BY ANYONE EXCEPT AS EXPRESSLY AUTHORIZED BY MEI. THE DOCUMENT SHOULD ALWAYS BE KEPT IN A SECURE PLACE AND SHOULD BE DESTROYED OR RETURNED TO MEI WHEN IT IS NO LONGER NEEDED.

SEE MEI MIP DATABASE FOR CHANGE HISTORY AFTER INITIAL RELEASE

TOOLING INFORMATION

DATE: JERRY A. (SCREW) TOOLING

<p>UNLESS OTHERWISE SPECIFIED:</p> <p>DIMENSIONS ARE IN MILLIMETERS OR DEGREES</p> <p>FINISH AND TOLERANCES</p> <p>UNLESS INDICATED TO OTHERWISE</p> <p>XX ±0.00 XX ±0.00</p> <p>XXX ±0.01 XXX ±0.01</p> <p>GEOMETRIC DIMENSIONS</p> <p>TOLERANCES UNLESS OTHERWISE INDICATED</p> <p>AND UNITS:</p> <p>DO NOT MEASURE OFF THE PRINT</p> <p>MATERIAL FINISH</p> <p>GENERIC - -</p> <p>SOURCE 1</p> <p>SOURCE 2</p> <p>FINISH - -</p>		<p>THIS DRAWING REPLACES:</p> <p>DATE: 04/20/09</p> <p>BY: JEFF THAWLEY</p> <p>DATE: 04/20/09</p> <p>BY: ED LAGAN</p> <p>DATE: 04/20/09</p> <p>PROJECT NUMBER: JEFF THAWLEY 04/20/09</p> <p>PUNCH 1.25</p>	<p>SCALE: 1:1.25 VOLUME: 000.000 (CUBIC MM) SHEET 1 OF 4</p> <p>SCALE: 1:1.25 VOLUME: 000.000 (CUBIC MM) SHEET 1 OF 4</p>
---	--	--	---

16 15 14 13 12 11 10 9 8 7 6 5 4 3 2 1

NOTES:

- 1.) DIMENSION UNITS ARE (INCH / MM IN CASE OF ROUNDING ERRORS) MILLIMETER DIMENSIONS ARE PRIMARY INCH VALUES ARE FOR REFERENCE ONLY.
- 2.) SEE DRAWING 252059025 FOR BILL ENTRY GUIDE DESIGN AND MOUNTING.
- 3.) SEE DRAWING 252050011 FOR CASSETTE LOCK SPECIFICATIONS.
- 4.) FLEXIBLE HANDLE AND HANDLE SUPPORTS MAY BE REMOVED IN APPLICATIONS WHERE SPACE IS RESTRICTED.
- 5.) REFERENCE DIMENSIONS SHOWN WITH ().

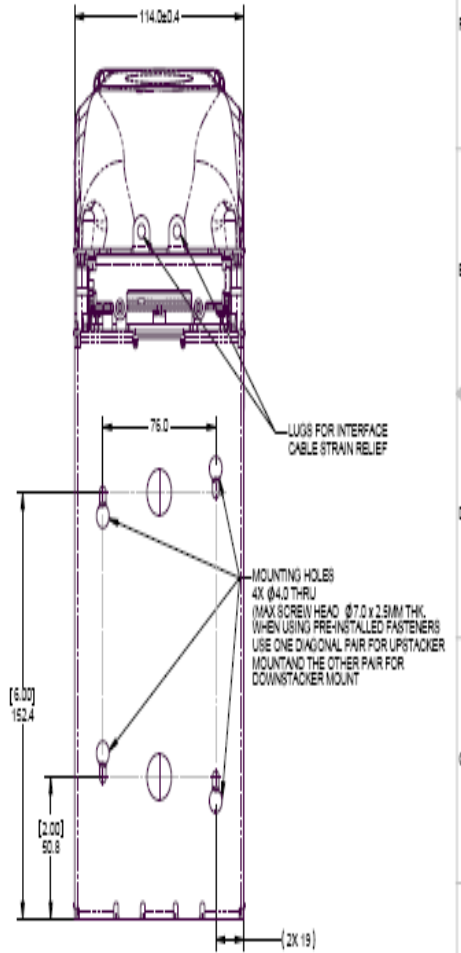
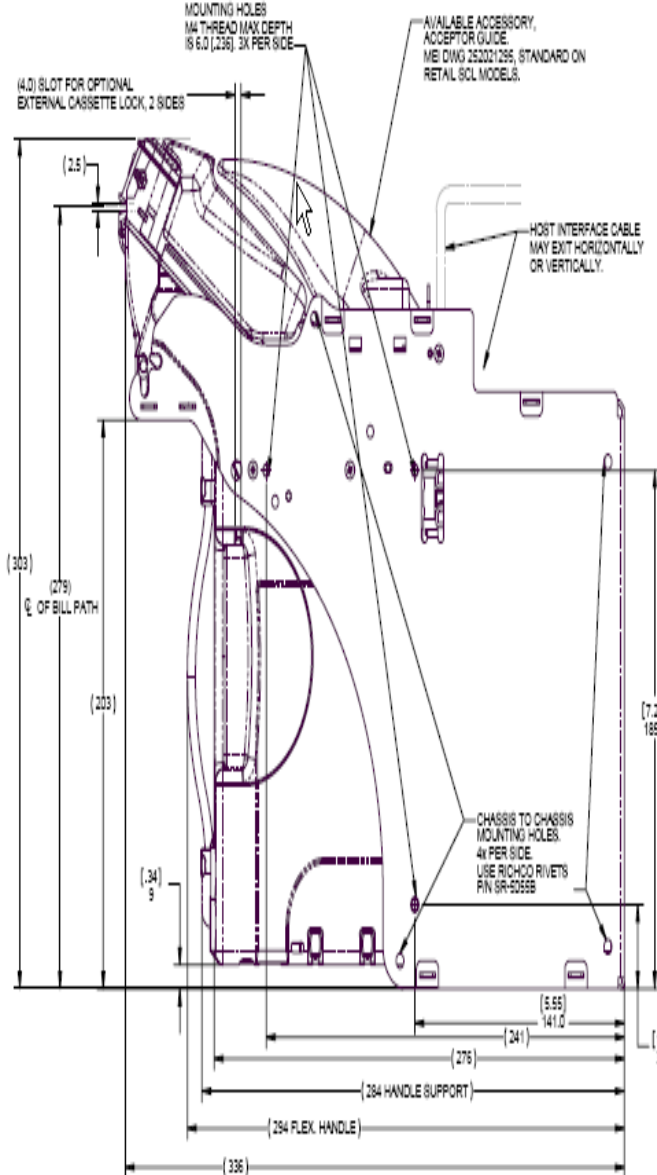
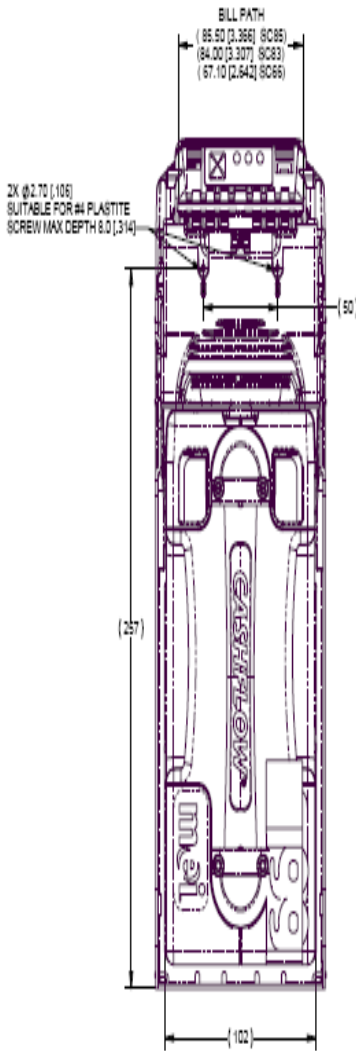
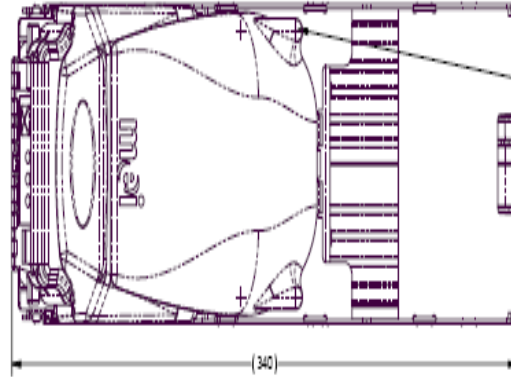

NOTICE OF CONFIDENTIALITY: THIS DOCUMENT AND THE INFORMATION CONTAINED IN IT ARE CONFIDENTIAL AND ARE THE PROPERTY OF MEI. THEY MAY NOT BE IN ANY WAY DISCLOSED, COPIED OR USED BY ANYONE EXCEPT AS EXPRESSLY AUTHORIZED BY MEI. THE DOCUMENT SHALL BE KEPT IN A SECURE PLACE AND SHOULD BE DESTROYED OR RETURNED TO MEI WHEN IT IS NO LONGER NEEDED.		SEE MEMBER DATABASE FOR CHANGE HISTORY AFTER INITIAL RELEASE
PREPARED FOR: REFERENCE		TOOLING INFORMATION
DATE: 2004-02-19	DESIGNER: [redacted]	TOOLING: [redacted]

MATERIAL / FINISH
 GENERIC --
 SOURCE 1
 .
 .
 .
 SOURCE 2
 .
 .
 .
 FINISH --

UNLESS OTHERWISE SPECIFIED:
 DIMENSIONS ARE IN MILLIMETERS OR DECIMALS
 TOLERANCE PRECISION
 LEADING DIMENSIONAL TOLERANCES
 1X ±0.10 2X ±0.15
 3X ±0.15 5X ±0.20 10X ±0.30
 GEOMETRIC DIMENSIONS AND TOLERANCES PER ANSI Y14.5M AND Y14.5-2002
 DON'T SCALE OFF THIS PRINT
 WITH THIS PROJECT: PUNCH 1.5

THIS DRAWING REPLACES:	REFERENCE PART NO.:		CASHFLOW SCL SERIES MECH. INTERFACE
DATE: 2004/02/02	DATE: 2004/02/02		
PROJECT NO: 252202001	DATE: 2004/02/02	SCALE: 1:1	DRWG NO: 000.000