

mei | cashflow®

Cashflow 7512i Operation & Service Guide

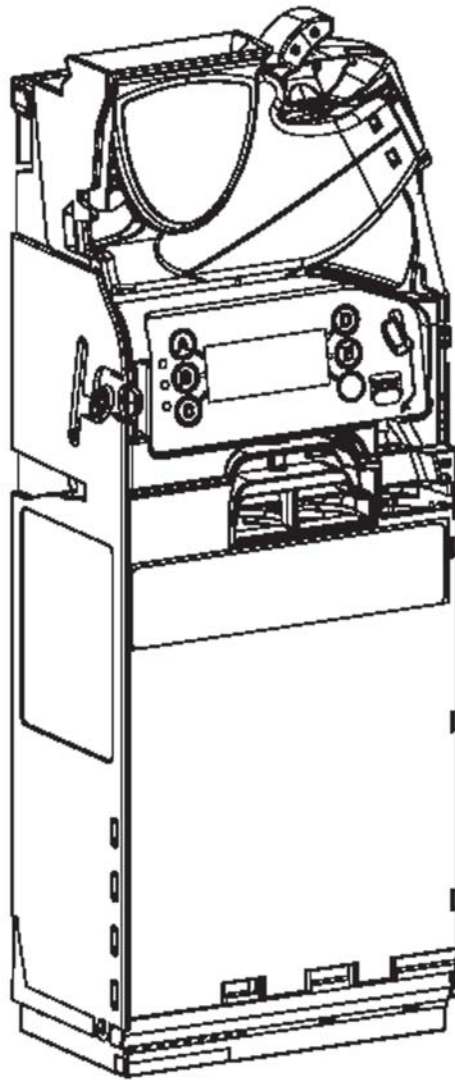

2008®MEI Inc. All Rights Reserved.

The MEI device, MEI CASHFLOW, MEI EASITRAX and SODECO are registered trademarks of MEI in the U.S. and other countries. Information is subject to change without notice. MEI has made every effort to assure that the information in this document is accurate. However, we cannot be held responsible for any errors or omissions.

Technical Support 1-800-345-8172
www.meigroup.com

CASHFLOW 7512i Page-1
Part # 794471001 G2

Contents

General Information	3
Introduction	3
Interface	3
Rated Operating Voltage	3
Installing the Coin Manager	4-9
Before you Begin	4
Alignment	4
Connection	5
Coin Manager with one harness	5
Coin Manger with two harnesses	5
Initial Power Up	6
Service Menu	6
Using the MMI Display	7
Accessing the Service Mode	8
Par	8
Par (Float)	8
Cassette	9
Custom Cassettes	9
Setup Section	10-15
Setup options	10
Messages	10
Par Options	11
Change Management	11
Vendor Options	11
Coin Configuration	11-13
Audit Configuration	13
General	14
Error Log	14
Test	14
Language	14
Setup Menu Map	15
Auditing the Coin Manager	16-22
How to Section	23-34
How to remove envelope icon from display	23
How to delete a token	24
How to understand tube terminology	25
How to reset the “Clean me” message	26
How to calibrate a coin cassette	27
How to float/par the coin manager	28
How to set-up auto float/par	29
How to set-up float to value	30
How to use snapshot float	31
How to select a payout algorithm	32
How to audit bill information on an MDB changer	33
How to setup tokens	34
Frequently Asked Questions (FAQ)	35-40
Cashflow 7512i Exploded Views	41-45
Cashflow 7512i Dimensions	46

GENERAL INFORMATION

Introducing the MEI CASHFLOW™ 7512i coin manager.
Principle components of the coin manager are:

1 Reject Lever

2 Acceptor/Separator. Sensors determine the authenticity of a coin or token. Accepted coins or tokens are routed to one of five tubes or the cashbox. Rejected coins or tokens are routed to the coin return cup.

3 LED's. Red, Amber and Green LEDs are used to indicate the status of the coin manager.

4 Keypad and message display. This is used to configure the coin manager, by using a menu.

5 Coin tube cassette. This is used to store and route coins for dispensing as change, thus enabling bills of high denomination to be accepted.

6 Dispenser. This dispenses coins being returned as change.

Interface

MEI CASHFLOW™ 7512i operates in machines that support the MDB interface*. MDB is a serial communication interface standard that developed into vending equipment since 1996. It allows for multiple devices to be added to a single connection on the vending machine control board, by linking one device to another parallel to the main MDB harness.

Rated Operating Voltage

Voltage: 34v d.c. 12W

The operating voltage of a MEI CASHFLOW™ 7512i coin manager is stated on the label of each product. The label is located on the left side of the coin manager. It must not be used with any power source other than that indicated.

The features of the Coin Manager include:

- In field changeable/configurable coin cassette
- Five auto-replenishing coin cubes (flexibility)
- \$1 coin payout
- LCD display panel - gives instant status of unit
- Patented coin inventory recognition
- MDB interface
- Ability to manage coin inventory to minimum levels

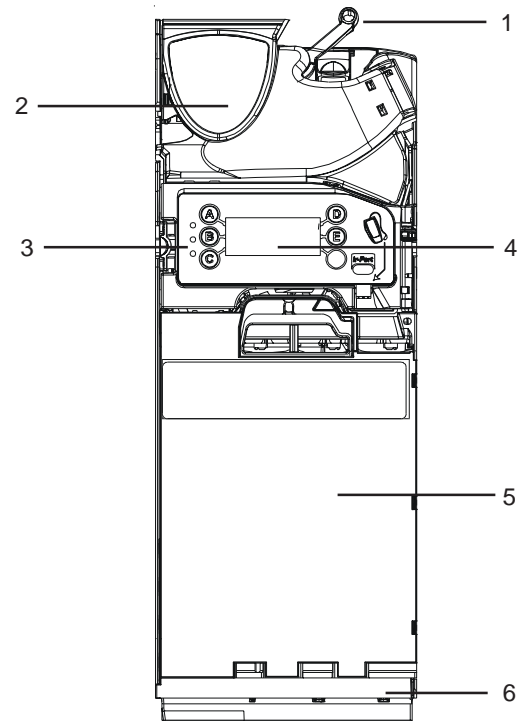

**Note: MDB (Multi drop bus) interface information can be found on NAMA's website located at www.vending.org*

INSTALLATION

Before you begin...

- Remove the coin manager from the packaging material. Inspect unit for physical damage that may have occurred during shipping.
- Turn OFF the power supply to the vending machine.
- Push and hold the yellow button on the top right (below reject lever) of the coin manager and tilt the acceptor assembly forward. You do not have to remove the cassette (See Fig 1).
- Once open, the mounting holes are accessible. Hang the coin manager on the mounting studs/screws, ensuring that the changer is mounted on all three studs/screws (See Fig 2).
- Tighten screws (if required) and close the acceptor assembly.
- Remove cassette by sliding two fingers in the yellow latch and lift the cassette outwards and upwards as shown in Fig. 3.
- Manually fill cassette with coins. Insure that coins are inserted into the proper tubes.

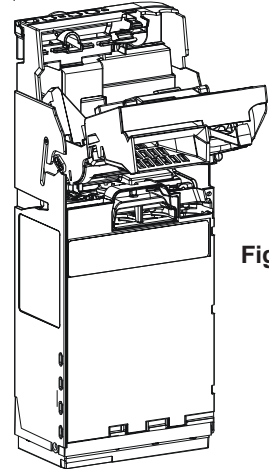
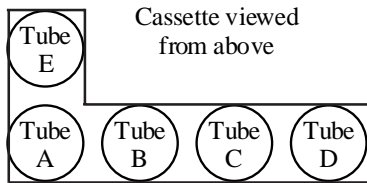
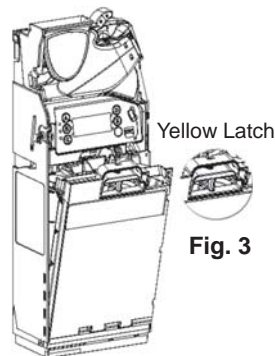

Fig. 1



Cassette viewed from above



Yellow Latch

Fig. 3

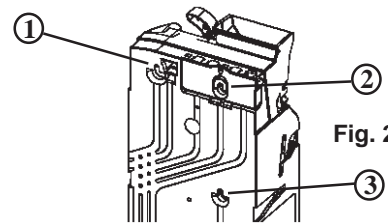

Fig. 2

Alignment

•Once the coin manager is installed, check that there is a small gap (2-4 mm) between the lever on the vending machine and the return lever on the coin manager (See Fig 4). Check that when you press the coin return lever on the machine door, it fully opens the acceptor lid on the coin manager then returns smoothly without holding the lid open.

•Check the alignment of the coin input chute and cashbox chute. Insert some coins to check that they enter the coin manager properly and exit into the return cup (See Fig 5). Ensure that the coin chute does not rest on or open the flight deck lid.

Most machines allow you to adjust the return lever, coin chute, and the return cup to align with the coin manager.

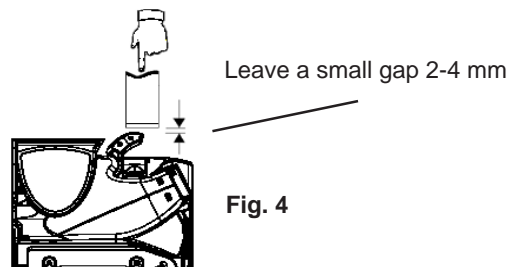

Leave a small gap 2-4 mm

Fig. 4

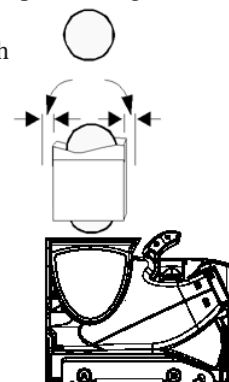
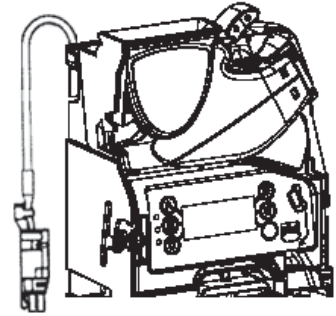

Fig. 5

Connection

The coin manager will be supplied with one or two harnesses. One connects the coin manager to the vending machine. The second harness, if present, allows for power and communication between the coin manager and another MDB device.



Coin manager with one harness...(Main)

- If you have a bill acceptor, connect the MDB harness coming from the coin manager to the bill acceptor's "Y" connector.

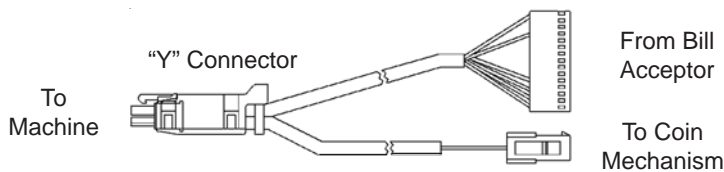

- If there is no bill acceptor, connect the coin manager harness to the harness coming from the machine's control board.
- Switch on power.

Coin manager with two harnesses... (Main and MDB Peripheral)

The purpose of having two harnesses (one male connector, one female socket), is that the 7512i coin manager has the ability to store bill acceptor audit data. The bill acceptor data can be viewed on the 7512i display. Connecting the bill acceptor to the coin manager enhances the coin management capabilities and allow you to collect critical business statistics (CBS is defined on page 19).

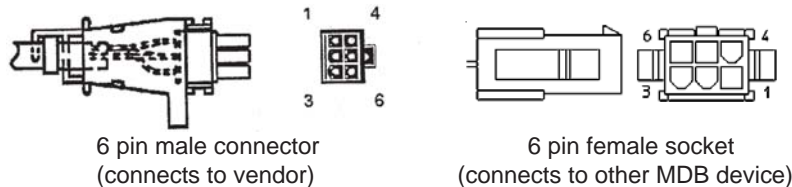

- Disconnect the harness connecting the bill acceptor to the machine's control board. Attach the male connector coming from the coin manager to the female connector coming from the VMC. Attach the female connector from the coin manager to the bill acceptor's male connector.

Note: There will be an unused MDB connector from the bill acceptor.

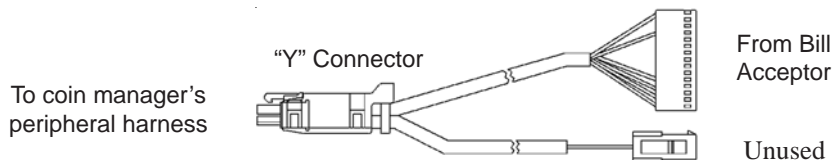

- Tuck any excess length of harnessing inside the machine. Make sure all harnesses are not trapped when the coin return lever is pressed or when the vending machine door is closed.

- Now you may switch "ON" the power to the vending machine.

Initial Power Up (First Time Out of Box)

The coin manager will power up and check to see how many coins are in each tube. If the tubes are empty the coin manager will alert you which tubes are low (See figure 6). You should fill the three lowest coin value tubes with a minimum of five coins per tube (i.e. On a 5,5,25,10,25 configuration, you would have to fill tubes ACD).



Fig. 6

Once you've filled the cassette with coins, the coin manager will measure the tubes for 5 seconds and display a happy face, an "OK", and the total amount of change in the tubes (See Fig. 7). Dispense some coins from each tube to check that all coins drop into the return cup properly.



Fig. 7

If **no** cassette has been defined, the coin manager, when powered up, will display a warning message indicating the cassette needs to be defined before the product will operate (See fig. 8).

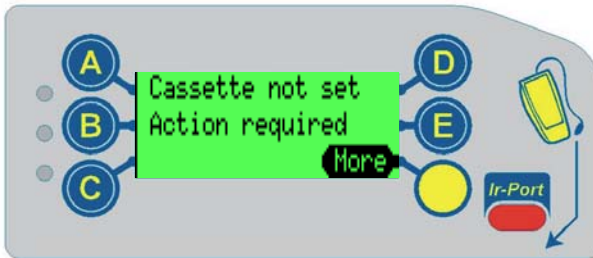

Fig. 8

The user needs to press the "more" key to proceed.

The user has two options:

- Enter the cassette model located on the front of the cassette (i.e. AB). The unit may be ordered with one of the cassette configurations shown on page 9.

or

- Insert a valid coin, then select the tube location (A-E) to which that specific coin is to be routed. Repeat procedure on all five tubes until all tubes have been assigned a coin. Press "Next", followed by "Accept".

Once you've defined the cassette, fill the cassette with coins. The coin manager will check tube capacity, then display a happy face, an "OK", and the total amount of change in the tubes (as shown in Fig. 7).

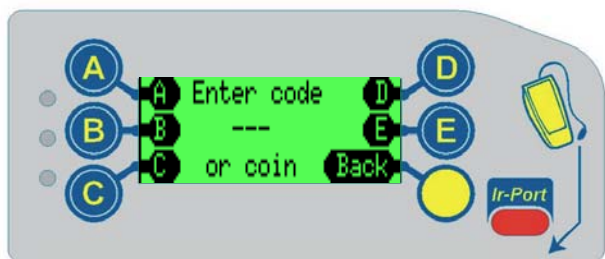

Fig. 9

Service Menu

The yellow button below the "E" is the mode key. The mode key provides access to all of the features of the coin manager.

When the yellow MODE key is pressed once, the user interface will enter Service Mode where features can be selected by pressing the keypad (See Fig. 10).

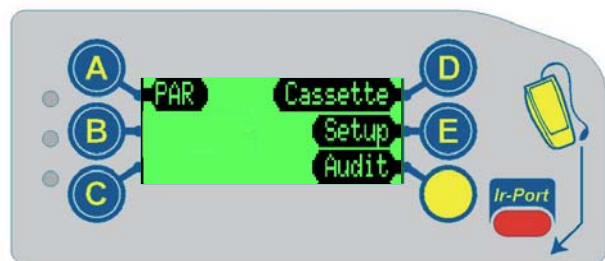
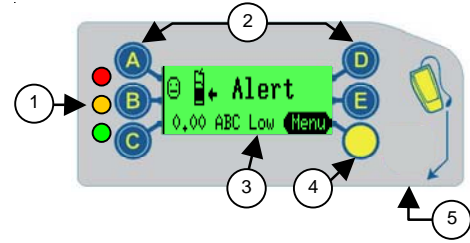

Fig. 10

After 5 seconds the screen will change slightly and the "audit" key will become the "Back" key.

Using the MMI Display

- 1 - 3 LEDs - Red, Amber, and Green provide changer status.
- 2 - Buttons A thru E - When the coin manager is in the idle state, the blue buttons can be used to dispense coins from the tubes. If however, the mode button is pressed before hand, these buttons are used to navigate through the service & set-up menu options.
- 3 - Display (LCD) - Displays warnings and menu information
- 4 - Mode Button - The mode button can be used to access the two configuration modes available. Service Mode and Set-up mode.
 - Service Mode: gives access to the most frequently used product configuration options.
 - Set-up Mode: gives access to general product configuration options that are required when setting up your coin manager.
- 5 - Service Connector - Allows you to connect a Cashflow programming Module (CPM) to the coin manager.



LED Light Codes

The 3 LEDs fitted on the coin manager provides up to the minute status information.



If all LEDs are off, then the coin changer has no power.. Check that there is power to the host machine and that the harness is connected properly. ○

During power up or when reset, the LEDs will cycle 5 times.





If a coin changer ever flashes alternate red and green , remove the coin changer, and send to a local service center.

Green LED Codes

A solid  means the coin manager is on and working properly.

Blinking  means coins are being measured.

1 blink  means a valid coin was accepted.

2 blinks  means an unknown coin was rejected.

3 blinks  means a valid coin that has been inhibited was rejected. You can program the coin manager or the vending machine to inhibited a coin.

Slow flashing  means the coin manager is in Set-up or Service Mode

Fast flashing  means the coin manager has a message available for display.

Amber LED Codes

Solid amber  means the coin manager is inhibited by the VMC.

1 flash  means there is a discriminator error

2 flashes  means there is an accept gate error

3 flashes  means there is a separator module top sensor or tube cassette error.

4 flashes  means there is a dispenser module error

5 flashes  means there is a low change alert

Accessing the Service Mode

A Quick press of the Yellow (mode) button will take you into the Service Mode menus. The display will change to show the available option available. (see picture below).

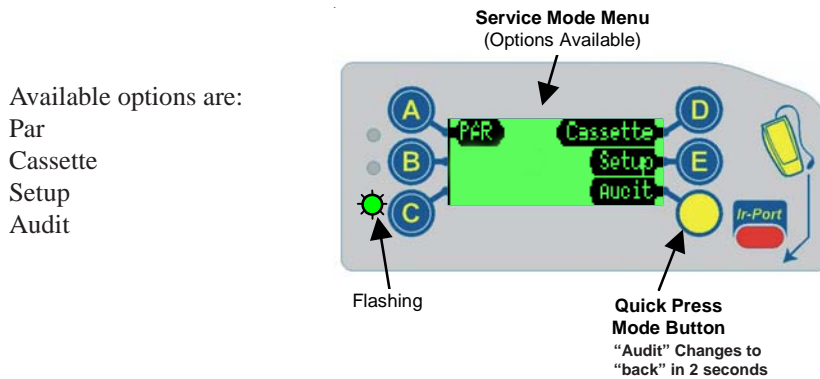

Par

If you press the **A** button in service mode, the coin manger will start par. The coin manager will either dispense excess coins or ask you to insert a specific quantity of coins into each tube to equal the set par value. (For more information on par options, refer to the set-up mode section).

PAR (Float)

The PAR default setting (comes set from the factory) is "PAR to Level". PAR to Level allows you set the level of each individual tube so that once the level is reached, further coins may be sent to the cash box.

The default PAR Level (from factory) is full tubes.

If you change the PAR setting to "PAR to Value". The default value is \$50.

Par to value looks at the total value of coins in all five tubes.

The PAR (or float) operation has three stages:

- Payout of any coins above the PAR
- Request insertion of coins that are below PAR
- Display Results

Cassette

If you press the **D** button in service mode, you enter cassette mode. In Cassette mode, you will need to enter a cassette code or insert a coin through the acceptor. The cassette mode allow you route coins to different tubes. You may choose a preprogrammed cassette or custom configure a cassette.

Pre-Programmed USA Cassettes

Key Code	TubeA	Tube B	Tube C	Tube D	Tube E
AA	10	5	25	25	5
AB	10	5	25	\$1	5
BA	25	5	25	25	25
BB	10	5	10	25	5
CC	Custom cassette 1 - defined in factory or by service tool.				
CD	Custom cassette 2 - define yourself using cassette teach.				
DAC	25	5	\$1	\$1	25
DCA	25	10	25	\$1	5
DCB	25	10	\$1	\$1	5
DCC	25	10	25	25	5
DCD	5	10	10	10	5
DCE	10	10	10	10	5

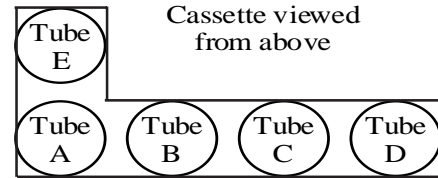

Custom cassettes:

You must always include at least one 5c tube in all custom configured cassettes.

Do not place the \$1 tube in position A or B.

Do not place the 25 cent tube in position B.

Do not place the 10 cent tube in position E

Coin	Tube Base Color	Max Fill (\$)	Manual Fill(\$)	Tube Position – OK
5c	Red	77 (3.85)	87 (4.35)	A,B,C,D,E,
10c	White	115 (11.50)	127 (12.70)	A,B,C,D,
25c	Black	84 (21.00)	96 (24.00)	A,C,D,E,
\$1	Blue	69 (69.00)	81 (81.00)	C,D,E,

Select the cassette option, Insert a nickel into the top of the coin manager. Select all tube locations (A-E) where you placed a nickel tube. Follow the same procedure with remaining coins for which a tube has been assigned in your custom cassette. Once all letters on the display have been replaced by a coin denomination press the next button. The display will ask you to accept / cancel the change. Once you accept the change press OK to complete the operation.

Setting or Changing Options

Setup

If you press the **E** button in service mode, you enter setup mode. In Setup mode a warning will appear asking you to press the A- B -C buttons to make sure you want to enter this menu. Once you press these buttons, you access to the following:

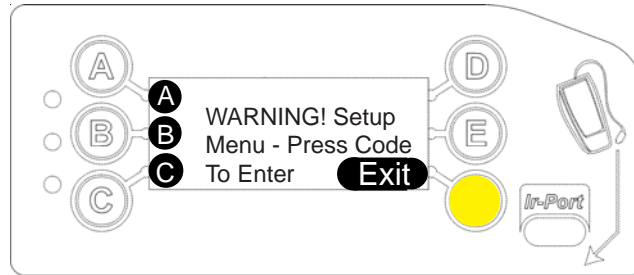

u to select par style (par to auto, par
ar to value).

- Messages*** *If a message is available setup mode will begin with this option to view the message. If no message is available, the setup mode will start with “par options”.
- PAR OPTIONS**
- CHANGE MGMT** Allows you to setup tube fill levels and coin payout mix to optimize coin return.
- VENDOR OPTIONS** Allows you to setup option that are specific to the Multi Drop Bus (MDB) interface.
- COIN CONFG** Allows you to setup token teach, security, coin setup, channel setup, exchange rate, and alarm timeout (0 - 1275 seconds).
- AUDIT CONFG** Allows you to view the machine id and serial number under the setup option, reset the ir pod password, and set the install date, edit report titles and edit interims in the printer option.
- GENERAL** Allows you to calibrate tubes, change coins being accepted, reset the clean-me level, save changer setting or restore the last saved settings.
- ERROR LOG** Allows you to view or reset the last 10 error logs recorded by the coin manager.
- TEST** Allows you to test the coin manager components, connectivity, and coin manager information.
- LANGUAGE** Allows you to change the language displayed (English, French, Spanish, Italian, Portugues, etc).

Defining each setup option:

- Messages*** Messages are the result of “tube wizard”. Tube wizard is an application that generates tube and cassette suggestions in any of the par options. These messages suggest different tube configurations based on the coin managers operation over previous weeks of constant operation. If coin demand changes or fluctuates over time, messages will appear suggestion changes.

Defining each setup option(continued):

PAR OPTIONS

Par is the level/value of coins that are to be left in the changer after the route person fills/services the coin manager. Three types of par options are: par levels, par value, and snapshot par.

Par to level

CHANGE MGMT

Tube fill level:

Fill to Max Capacity - means the tubes will fill to capacity. Capacity for each coin are: 5c - 77 coins, 10c - 115 coins, 25c - 84 coins, \$1 - 69 coins.

Fill to Par- means that additional coins, that exceed the setup amount, will be routed to the cashbox.

Large Coins - means "Best for customer" Fewest coins paid out to consumer.

Small Coins - means "Best for operator" Small coins dispensed more often. Less small coins directed to cashbox.

Change machine - Acts like a bill changer machine. Will give a mix of coins (i.e.\$1=3x25c,2x10c,1x5c).

VENDOR OPTIONS

Optimize change:

Off / On - If "On", the coin manager decides the best mix of change to dispense.

Levels:

Level - MDB protocol has Level 2 and Level 3 (MDB comms type). Keep always in Level 3. Consult MEI technical support for more detail regarding this option.

Coin Counts:

As TRC0004 - reports first 3 coins as zero as does the TRC6512.

As CF 1234 - reports all coins in tubes as does the CF690 (Euro).

Par coins:

Hide / Report - When filling, par coins credit is not reported in the hide mode. In report mode par coins are credited to the machine.

Coin Scaling:

Should be set to 5 for US and Canada. Never change this setting.

Decimal Pnt:

Should be set to 2 for US and Canada. Never change this setting.

Country:

Should be set to 0001 for US and Canada. Never change this setting.

COIN CONFG

Token Teach:

Select a location (1 - 6)

Value token - Enter value, then name then insert 32 samples

Vend token - Enter name, then insert 32 samples

Reject token - Enter name, then insert 32 samples

Slug - Enter name, then insert 32 samples

Security (changes settings for all 32 coin channels):

Hi acceptance - Default setting. Should remain in this mode unless frauds occur

Hi security - Tighter acceptance window. Used if frauds occur.

Coin Setup:

Allows operator to edit values (i.e. US and/or Canadian), enable/disable acceptance and change coin type (coin, token, slug).

32 coin channels available.

Defining each setup option(continued):

COIN CONFG

Channel setup:

Channel 1 -32 (enabled / disabled)

Acceptance parameters for an individual channel can be set.(i.e. changing the US.10 cent coin from high acceptance to high security).

Exchange rate:

Set the exchange rate between two currencies (i.e. exchange rate from US\$ to CN\$ is set at US\$1 to CN\$1.5819). The operator must set and maintain the exchange rates as they fluctuate.

Cleanme level:

Default level @ 59%. A cleanme message will appear if acceptance falls below this set value. An operator may change the percentage.

This percentage is based on:
$$\frac{\text{\# of accepted coins out of the last 64 coins}}{\text{the last 64 coins inserted}} * 100\%$$

Alarm timeout:

Operator may set unit to reject coins in increments of 5 seconds after a fraud is detected. Default has this feature turned off.

Alarm time x 5 seconds (i.e. if alarm time is set a “2”, coins will be rejected for 10 seconds after a fraud is detected).

The following types of tokens can be taught:

- **Vend token** – the token is reported as an MDB TOKEN to the machine, which typically treats it as a free vend token, for more precise information on vend token handling refer to the vending machine manual.
- **Value token** – the token is assigned a value (as per a coin) and accepted and routed to cashbox. As MDB does not distinguish between coin credit and token credit it will be possible to get change or returned monies having inserted a value token.
- **Reject vend token** – the token is reported as an MDB TOKEN to the machine, which typically treats it as a free vend token, for more precise information on vend token handling refer to the vending machine manual. However, this token will always be returned to the customer in the reject chute even though it is credited as being accepted as a token. A typical application would be using a token to open a newspaper vendor on a street corner.
- **Slug** – this allows a fraudulent object to be taught and inhibited, to prevent it being accepted and credited as a valid coin.

See token diagram on the next page.

Defining each setup option(continued):

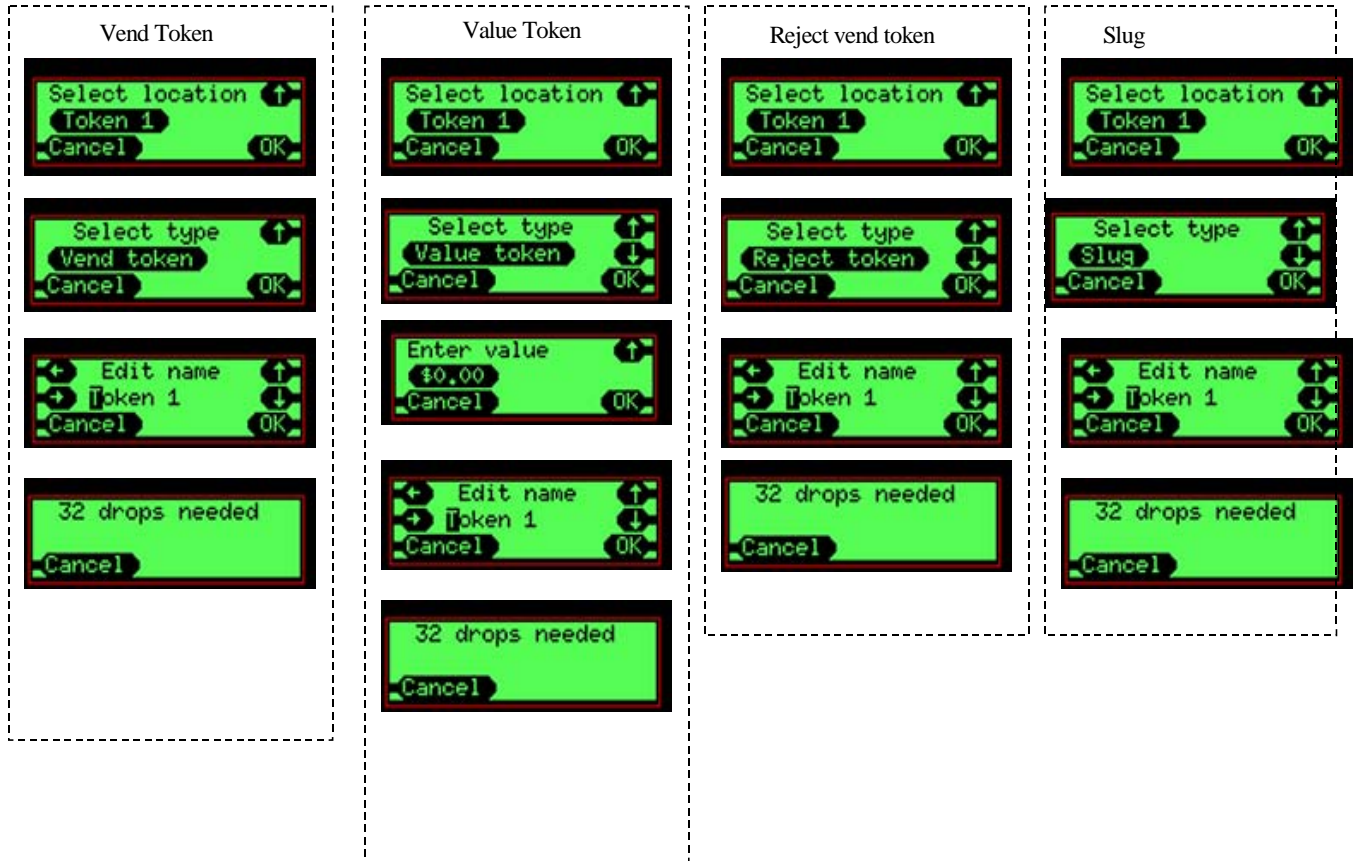

AUDIT CONFG

Setup:

Reset audit - None, interims, totals + Interims

None - means no reset after collection of audit information

Interims - all interims values are reset after each collection

Totals + Interims - All values (including historical) are reset after collection. Operator decides on feature's use.

Machine ID: (default is unit serial number)

Operators may change this number to suit needs. The machine ID will appear in DEX readings.

IR password (Reset):

This option is for remote IR port. Does not affect the IR port on the changer keypad.

Printer:

The entire printer feature sets printed report parameters if an optional printer is installed on the changer.

Report type

Basic (print basic report)

Interims (prints basic + interims)

Free Vends (prints all three reports)

Report Languages - English, French, German, Dutch, Spanish

Report Title

Edit as needed.

Install date

Edit as needed.

Defining each setup option(continued):

GENERAL

Accept / pay:

Allows operator to change between coins accepted and coins paid out from tubes.

Calibrate tubes:

Should only be performed by service personnel!

Settings:

Allows operator to set configuration of changer and save. If settings are unknown, operator can restore to last saved setting.

Save (save new configuration settings)

Restore (restore last saved settings)

ERROR LOG

View / reset:

Allows operator to view last 10 error records. These are shown from newest to oldest.

Errors in log may be erased (reset).

TEST

Auto / Manual / Info:

Auto test - performs an auto test of all components of the coin manager. Upon completion of a successful test, the changer will display “passed”.

Manual test - Allows you to perform individual test of the components.

The components are:

Coin sensors (coin sensor idles)

Accept gate (checks accept gate sensor)

Gate Sensor

Separator

Cassette

Dispenser

Temperature

Comms

Other

Info:

In the info mode, the following information is provided for servicing purposes.

Software version, Hardware version, Boot loader version, coin manager serial number, acceptor serial number.

LANGUAGE

Language is set at factory. Operator can change as needed. The following languages are available.

English, French (Euro or Canadian), Spanish (Spain or Latin American) , Dutch, Portuguese, Italian.

Defining each setup option(continued):

Setup Menu Map

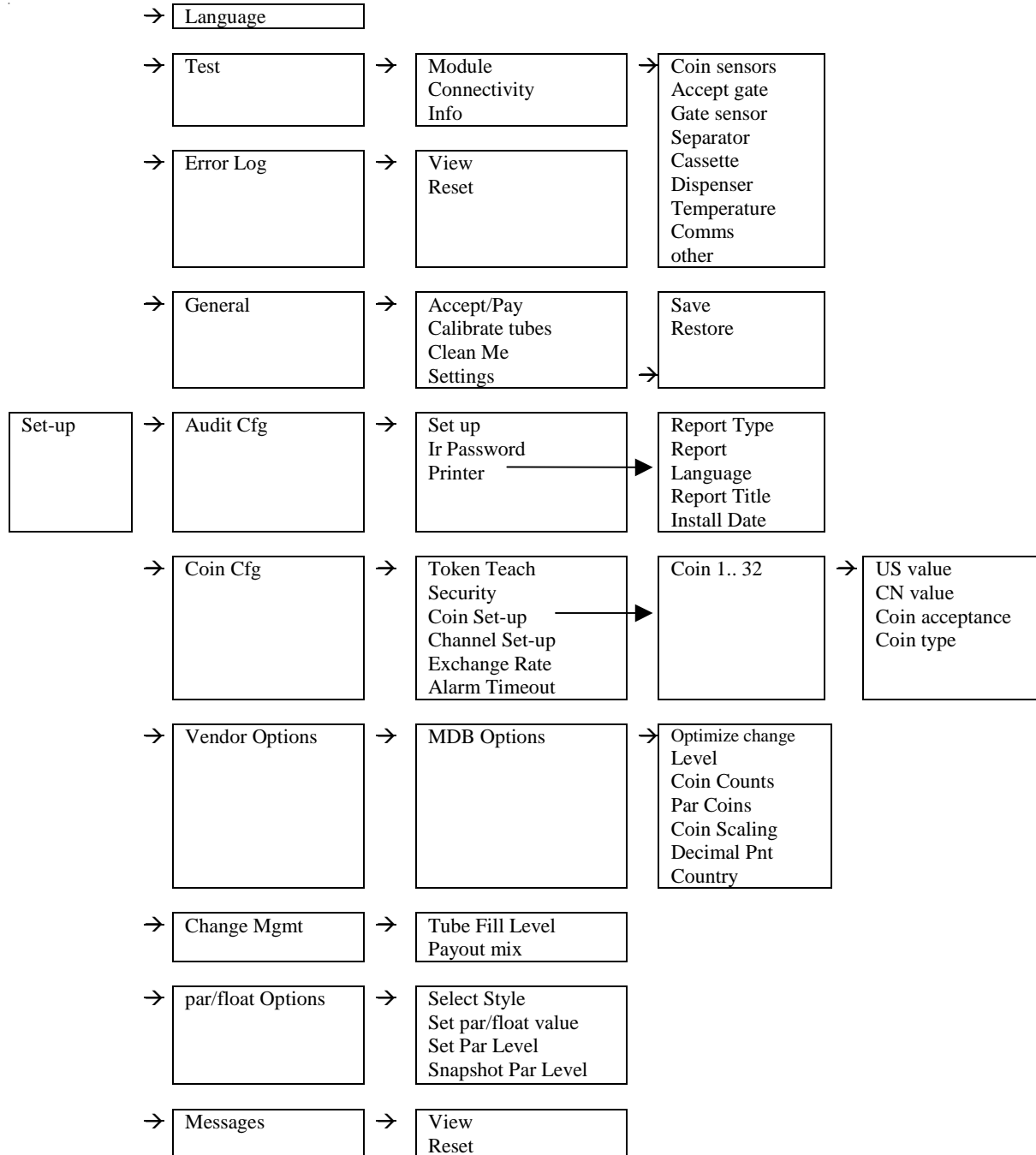

Audit

If the yellow Mode Key is pressed twice in quick succession (with cassette in), then the display will show audit information. Each message will be shown for 3 seconds. The screen can be frozen on the display by pressing “pause”. The “pause” button will then alter to become a “resume” button . When the “resume” button is pressed, the screens will continue to show, in sequence, the audit information.

Audit information displayed:

Value of Cash to Cashbox	Annualized Estimates
Value of Cash to Tubes	Sales Lost in Exact Change
*Value of Bills Accepted	Percentage time in Exact Change
Value dispensed as change	Value of Sales in Exact Change
Value of manual dispense	Value of Sales with Change Available
Total Tube value	Number of Sales in Exact Change
Tube A Count	Number of Sales with Change Available
Tube B Count	Average Price with Change Available
Tube C Count	Time In Change
Tube D Count	Time With Change
Tube E Count	Time Disabled by VMC

* “Value of Bills Accepted” will be present in the audit information, only if the bill acceptor is attached to the coin manager’s optional MDB peripheral harness.

Audit Screens

There are three types of data shown. The first set of screens show historical data (sometimes referred to as totals or non-resettable values). These values are set to zero when the product is built and then always increase. The second set of screens show the current status of the tube counts and the third set show estimates for yearly performance.

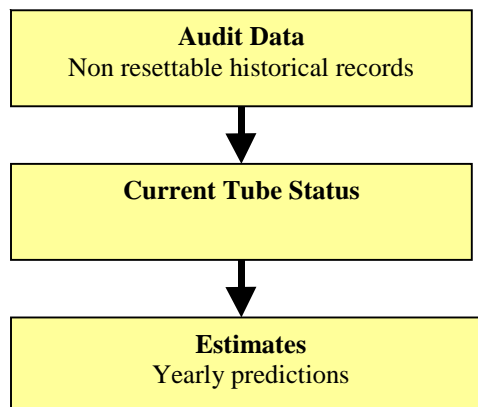

Audit(Cont.)

The first few screens show audit information that has been recorded from actual events. They are a historical record of what has occurred since the product was first built.

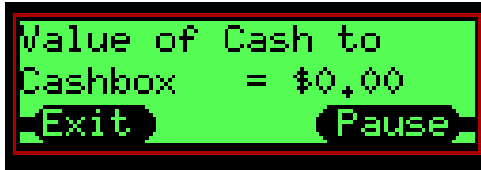

EVA DTS (DEX) reference CA306

Value of Cash To Cash Box Since Initialisation

Value of cash sent to the cashbox. Does not include value of free vend tokens. Non-Resettable.

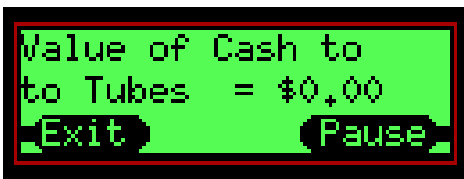

EVA DTS (DEX) Reference CA307

Value of Cash To Tubes Since Initialisation

Value of all coins sent to the inventory tubes, including sales and manual fill modes. Does not include value of free vend tokens. Non-Resettable.

EVA DTS (DEX) Reference CA308

Value of Bills In Since Initialisation

Total value of all bills (banknotes) accepted. Does not include value of free vend tokens. Non-Resettable.

NOTE: This screen will only be shown if a bill validator is currently attached (or has been previously attached) to the MDB peripheral connector. The changer cannot record audit information if the bill validator is connected directly to the vending machine.



EVA DTS (DEX) Reference CA403

Value of Cash Dispensed Since Initialisation

Total value paid out as change plus the value manually dispensed. Non-Resettable.

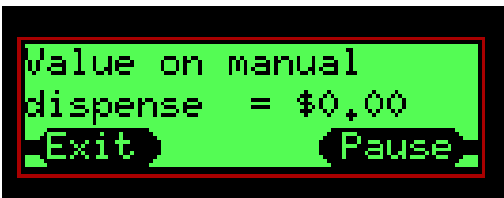

EVA DTS (DEX) Reference CA404

Value of Cash Manually Dispensed Since Initialisation

Total value dispensed manually. Non-Resettable.

Audit (Cont.)

Current Tube Information

The next few screens show information that describes the current state of the coin tubes.

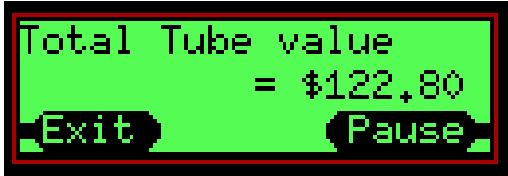

Total Tube Value

This is the total currency value of all the coins stored in the entire cassette.

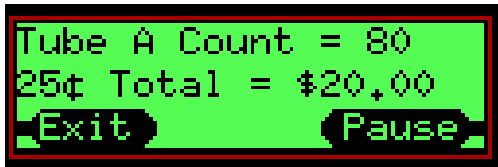

Tube A Count

This screen shows the number of coins in tube A e.g. 80 The type of coin e.g. 25 cent. The total value of coins in this tube \$20.00 (i.e. $80 \times 25c = \$20.00$)

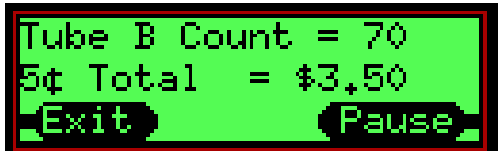

Tube B Count

This screen shows the number of coins in tube B, the type of coin and the total value of coins in this tube

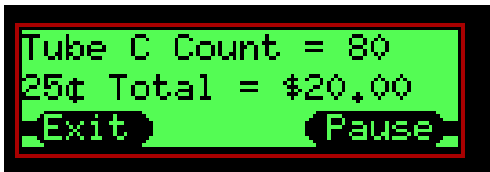

Tube C Count

This screen shows the number of coins in tube C, the type of coin and the total value of coins in this tube

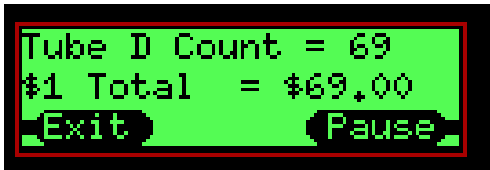

Tube D Count

This screen shows the number of coins in tube D, the type of coin and the total value of coins in this tube

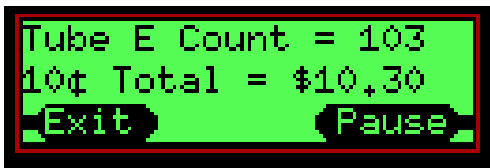

Tube E Count

This screen shows the number of coins in tube E, the type of coin and the total value of coins in this tube

Critical Business Statistics (CBS) - Estimates of Yearly Performance

This information provides annualized estimates of product performance and is based on a limited amount of information. The product collects data up to the last 28 days and makes yearly estimates based on this. However this information may not be totally accurate for the following reasons -

a) As the MDB protocol does not give the changer full knowledge of the vend cycle, the CF7XXX has to make some assumptions on when and what data to collect (i.e. when vends occur and how much they cost.).

Audit (Cont.)

Critical Business Statistics (CBS) - Estimates of Yearly Performance

b) The unit will store data for up to the last 28 days and will extrapolate this to give the yearly estimates, 1 full day of information is sufficient to start the process. Therefore predictions based on a small amount of information (less than 28 days or small number of transactions) may give wildly inaccurate predictions. This also does not account for any seasonal variation.

c) **Exact change** is when the changer has less than 5 tube coins of any of the lowest three coin denominations This may be a different algorithm to that used in the vending machine so the light on the front of the machine may not reflect what the changer thinks is happening.

d) If a tube is not in use (dispenser jam or tube jam) then the count for that tube is set to 0 and if it is a sole low denomination tube this will cause the changer to consider it is in exact change for 100% of the time.

e) If bills are used to pay for products and the validator is not connected to the changer MDB peripheral connector then some of yearly estimates will be wrong.

GUIDANCE NOTE: CBS information is not audit data and must be treated separately. As it is based on estimations it should really be used as a guide only.



This message is shown for a few seconds as a prompt that the next few screens of information are estimates for the upcoming year.



Sales Lost in Exact Change

This value is an estimate of how much sales will have been lost because customers may have been deterred from using the machine because the exact change light is on.

This figure is calculated by comparing the daily rate of sales when the exact change light is on vs. daily rate of sales when exact change light is off then scaling this figure to be a yearly estimate.



Percentage Time in Exact Change

This is a computation of the % time the changer was low in change over the monitored period.

This percentage is computed using the actual measured amount of time in exact change over the monitored period and the duration of the period.

Audit (Cont.)

Critical Business Statistics (CBS) - Estimates of Yearly Performance

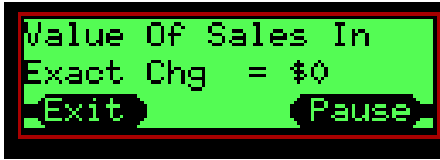

```
Value Of Sales In
Exact Chg = $0
Exit      Pause
```

Value of Sales in Exact Change

This is a yearly estimate of how much product will be sold when the changer deems it is in exact change.

Computed by averaging the amount of sales in exact change over the monitored period then scaling it to a yearly figure.

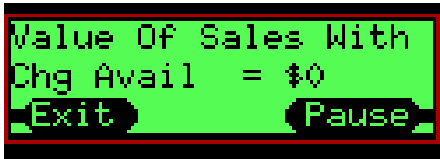

```
Value Of Sales With
Chg Avail = $0
Exit      Pause
```

Value of Sales With Change Available

This is a yearly estimate of how much product will be sold when the changer deems it has change available.

Compute an estimate by averaging the amount of sales when change is available over the last period



```
Num Of Sales In
Exact Chg = 0
Exit      Pause
```

Number of sales in Exact Change

This is a yearly estimate of how many products will be sold when the changer deems it is in exact change.

Averages the number of sales when in exact change light over the monitored period then scales it to a yearly figure.

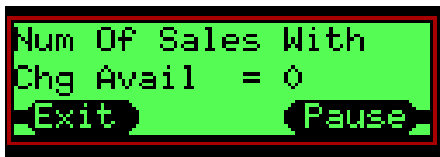

```
Num Of Sales With
Chg Avail = 0
Exit      Pause
```

Number of sales with Change Available

This is a yearly estimate of how many products will be sold when the changer deems there is change available.

Averages the number of sales when not in exact change light over the monitored period then scaling it to a yearly figure.



```
Average Price With
Chg Avail = $0.00
Exit      Pause
```

Average Price With Change Available

This is computed by dividing total value of sales by the number of sales to get an average price.

Notes:

This figure may create a value which is not a multiple of valid coins e.g. 21 cents, this is likely to occur on vending machines that have more than one price. The value of a sale is not available over MDB and so the changer has to estimate this based on coins inserted and paid out. This simple estimation will not be correct if the machine is in multi vend mode, a bill validator is attached directly to the machine or any other non standard set-up.



```
Time With
Chg = 0 Secs
Exit      Pause
```

Time With Change Available

This is a yearly estimate of how long the changer will be operating with change available (i.e. exact change light OFF)

This is based on a daily average time with change available scaled to a yearly figure.

Audit (Cont.)

Critical Business Statistics (CBS) - Estimates of Yearly Performance

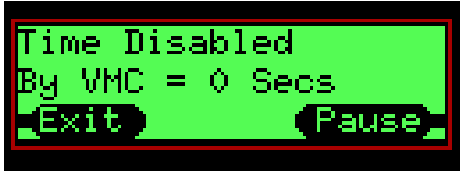

Time Disabled by VMC

This is an estimate of how long in a year the machine will be disabled. This could be because of machine faults, sold out of product, jams etc

The average daily time disabled is scaled to make a yearly figure.

Notes

This excludes brief periods (less than 30 seconds) typically when the product is being vended

The changer does not have a real time clock so only measures time when it is powered on. If the machine is switched off at night and operates correctly during the day the changer will measure it as never being disabled.

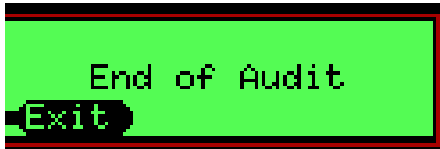

End of Audit

This message indicates there are no more screens of information

CBS Yearly Estimate Formula

This section contains more detailed formula used in the computation of the CBS yearly estimates.

The following items are monitored during the monitoring period (which may be upto 28 days long) and are used as a basis for the estimates:

- Value of Sales
- Number of Sales
- Duration in Exact change
- Value of Sales when in exact change
- Number of Sales when in exact change
- Duration disabled by vending machine
- Elapsed time (time when the changer is powered on)

Sales Lost in Exact Change

$\text{SalesValueDuringOK} = \text{Sum of sales for last period} / \text{number of days in the period}$

$\text{SalesValueDuringEC} = \text{Sum of sales for last period} / \text{number of days in the period}$

$\text{SalesValueECPerDay} = (\text{SalesValueDuringEC} * \text{ONE_DAY_IN_MINS}) / \text{MinsInECCondition};$

$\text{SalesValueOkPerDay} = (\text{SalesValueDuringOK} * \text{ONE_DAY_IN_MINS}) / \text{MinsInOKCondition};$

Yearly sales lost in exact change = $(\text{SalesValueOkPerDay} - \text{SalesValueECPerDay}) * 365$

Audit (Cont.)

Critical Business Statistics (CBS) - Estimates of Yearly Performance

Percentage Time in Exact Change

Total time in exact change = sum of time in EC for last period

Average time per day in EC = total time in exact change / number of days in the period

Percentage time in exact change = (average time per day in EC/time for 1 day) * 100

Value of Sales in Exact Change

Daily sales in EC = sum of sales when EC ON in last period/ number of days in last period

Yearly sales in EC = daily sales in EC * 365

Values of Sales With Change Available

Daily sales with change available = sum of sales when EC OFF in last period/ number of days in last period

Yearly sales with change available = daily sales with change available * 365

Number of sales in Exact Change

Volume of daily sales with EC ON = sum of volume of sales when EC ON in last period/ number of days in last period

Yearly volume of sales with EC ON = volume of daily sales with EC ON * 365

Number of sales with Change Available

Volume of daily sales with EC OFF = sum of volume of sales when EC OFF in last period/ number of days in last period

Yearly volume of sales with EC OFF = volume of daily sales with EC OFF * 365

Average Price With Change Available

SalesValueDuringOK = sum of value of sales in the last period while EC is OFF

SalesNumberDuringOK; = number of sales in the last period while EC is OFF

average_price = SalesValueDuringOK / SalesNumberDuringOK;

Time With Change Available

SecsInECCondition = sum of time in exact change in last period

Daily average time in EC = SecsInECCondition / number of days in last period

Daily average time with change available = Number of seconds in a day - Daily average time in EC

Yearly Time with change = Daily average time with change available * 365

Time Disabled by VMC

Total time disabled = sum of time disabled in the last period

Average daily time disabled = total time disabled / number of days in the period

Yearly time disabled = average daily time disabled * 265

How to Section

How to remove envelope icon from display

Symptom: Envelope icon appears on display
Cause : SMS message available for reading
Fix: View, action and delete SMS message

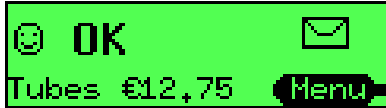

The changer will indicate an SMS message is present as follows:

- Green LED flashes fast continuously
- Envelope icon appears on the display

The system reports the presence of an SMS message when:

- The operator has left a message for another operator/user
- Tube Wizard is recommending a change to cassette configuration



To view message(s):

- Press **Menu**
- Press **Setup**
- Press **abc**
- Press **Select** to choose messages
- Press **Select** to view messages
- Use **Up/Down** arrows to access messages



To delete message(s):

- Press **Menu**
- Press **Setup**
- Press **abc**
- Press **Select** to choose messages
- Press **Up Arrow**
- Press **Select**
- Press **Accept** to delete all messages



NOTES:

The same Tube Wizard message is not repeated in consecutive weeks for the same cassette - even if the recommendation made is still valid. Changing the cassette model resets the recommendation system.

How to Section

How to delete a token

Symptom: Want to remove a previously taught token

Cause : Token was previously taught and accepted

Fix: Follow this procedure to delete the token data

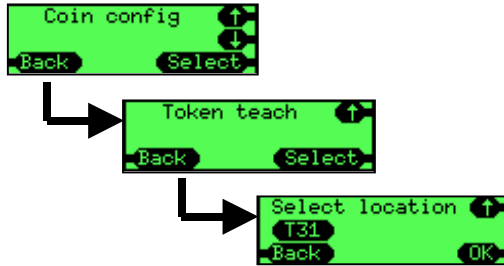

Enter token teach by:

- Press **menu** then
- Press **Setup** then
- Press **abc**
- scroll to the “Coin cfg” menu and
- Press **Select**.
- Scroll to “Token Teach” menu
- Press **Select**.

Select the required token by:

- using the **up** and **down** keys
- press **OK**.



Select the type of token as:

- **Delete** - this will delete data for the existing token in this slot



A confirmation screen will be displayed:

- Press **Accept** to delete the token

When a token has been deleted it will

- Delete the data that was used to validate what object it was
- Delete the type of token
- Delete the token description (text string)

How to Section

How to understand tube terminology

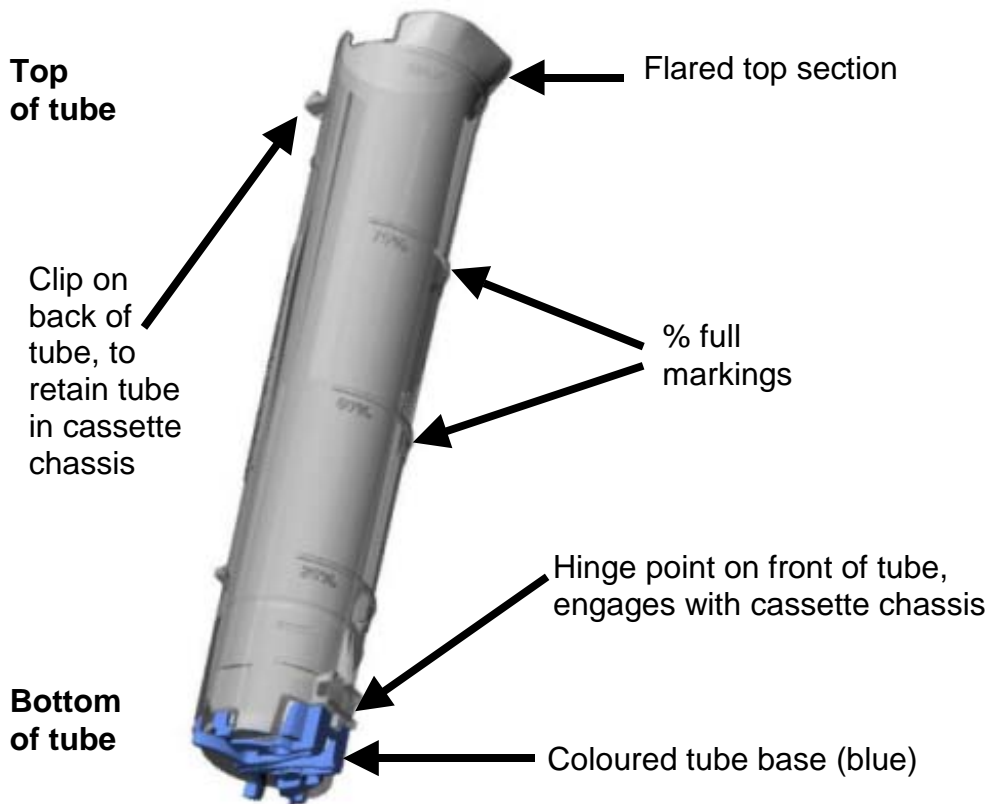

Tube References (Soft Options)

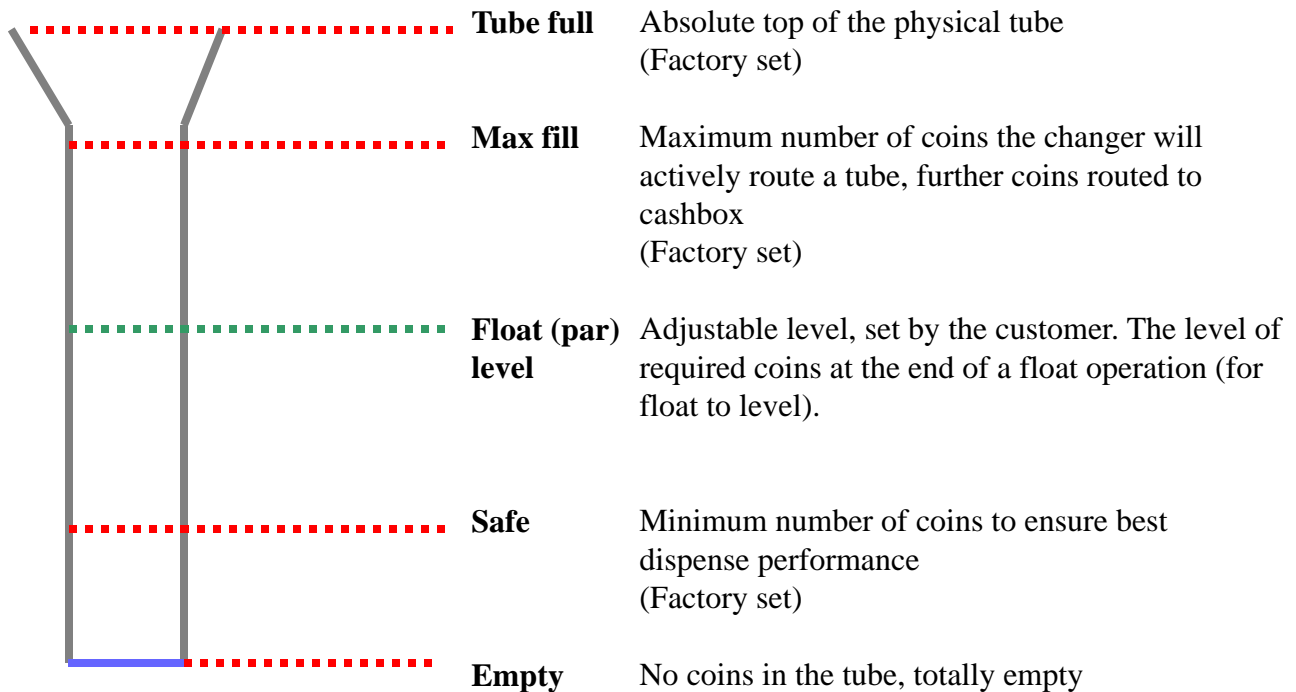

How to Section

How to reset the “Clean me” message

Symptom: Changer indicates it requires the deck to be cleaned

Cause : Dirt build up on the coin flight deck

Fix: Follow the procedure below to Clean

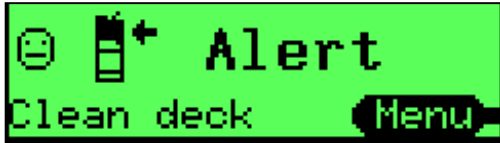

Changer displays a message indicating it needs cleaning because it has detected that recently (in the last 64 insertions) a lot of coins are not being discriminated as a valid coins



Open the lid
wipe both surfaces of the coin entry with a damp cloth
Close the lid

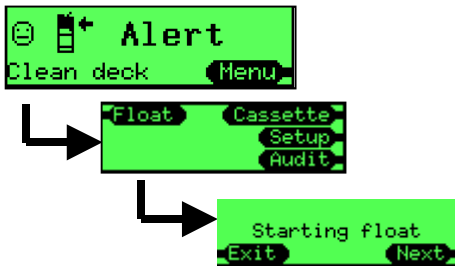

Press **menu**
Press **float** on 7900 or par on 7512
Press **A** (there is no prompt by the A key)

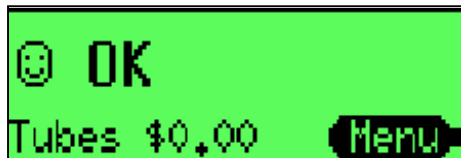

The changer now displays it is OK

How to Section

How to calibrate a coin cassette

Symptom: Changer indicates the cassette has not been calibrated

Cause : The changer has not been previously calibrated with that cassette configuration

Fix: Follow the procedure below to perform the calibration

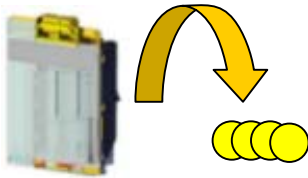

If the display indicates a cassette is un-calibrated or you want to improve the performance of the coin level sensing system by calibrating the exact cassette that is fitted to the changer then follow this procedure.

Remove the cassette and check it is empty then refit it.



Press **menu** then setup then abc

Scroll to the “General” menu then press **Select**

Scroll to the “Calibrate tubes” menu then press **Select**.

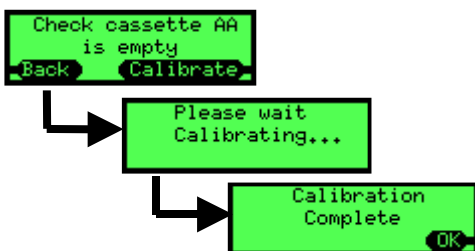

It will prompt you to check the corresponding cassette is fitted, if it is then press **Calibrate** , otherwise press **Back** and program the correct cassette code before restarting this procedure.

The changer will check each tube at least twice so there will be at least 10 clicks.

It will display a message when it has finished, press **OK**.



Press the **Back** key repeatedly to exit the menu, the main screen will now be shown with no un-calibrated warning.

How to Section

How to float/par the changer

Symptom: Changer has more or less coins than the target float condition

Cause : Changer has paid out and received coins since last being visited

Fix: Float the changer as described

The float process involves two stages:

- (a) Dispense of excess coins
- (b) Addition of insufficient coins

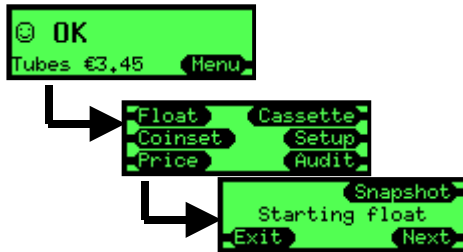

If there is no action to be performed for a stage then it will automatically move onto the next stage.

To start the float operation:

- Press **menu**
- Press **float**

The changer will display a screen indicating it is about to start the float process. Either

- Wait 2 seconds or/
- Press the **Next** key

(a) Dispense excess coins

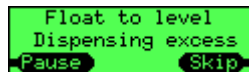

The changer will now dispense any excess coins, that is extra coins in the tube that are above the float setting. As coins are dispensed remove them from the coin return on the machine. If the coin return fills up with coins the dispense process can be paused (then resumed) by either:

- Press **Pause** key or/
- Press the reject lever

When all the excess coins have been dispensed the changer will move to stage 2 and ask the user to insert any additional coins it requires to achieve the float condition.

(b) Add extra coins

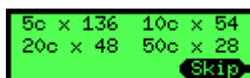
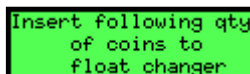

Insert the requested coins into the changer through the validator, the count of how many coins are required will decrease as coins are inserted. When sufficient quantity of a coin have been inserted it will stop prompting for that coin and reject any more of that type.

When all coins have been inserted it will display a message indicating that the float condition has been achieved.

It is possible to skip stages and not insert all the required coins, if this is done a different message will be shown at the end indicating the float condition was not achieved.

How to Section

How to set-up auto float/par

Symptom: Too much money in changer tubes
Cause : Manually set float/par levels are too high
Fix: Use auto float/par and set it up as described

What is Auto Float/par?

The aim of this algorithm is to have no settings for the customer to setup or compute and the changer to operate with the minimum amount of money in the tubes but ensuring the exact change light is rarely lit and that change is available for vends.

How Does it work?

The algorithm uses probability calculations to reduce the chance of the exact change light coming and monitors prices and whether bills are used to determine the fewest number of coins with the best optimal mix.

Will it work immediately?

No, it requires some time to gather information on how the tubes are being used, during this time it will run the tubes at their maximum level to ensure there is always enough change.

How do you Set-up Auto Float?

Use the keypad and screen to enable this function by:

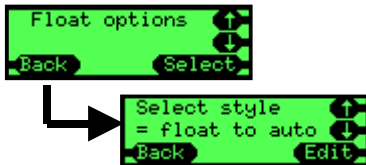

- Press Menu
- Press Setup
- Press abc
- Scroll to the item "Float options" then press Select
- Scroll to the item "Select style" then press Select
- Press Edit
- Use the up or down keys to alter the setting to "Float to auto" then press OK

How to Section

How to set-up float to value

Symptom: Want to improve coin mix in the tubes but keep same value in the tubes

Cause : Manually set float to level not working well enough

Fix: Use float to value to allow changer to compute coin levels

What is Float to value?

The aim of this algorithm is for the customer to have a simple setup and audit process i.e. they want \$xx in the tubes but for the changer to compute and dynamically alter the ratio of coins in the tubes to give the best mix of coins ready for change.

How Does it work?

The algorithm continually computes coin levels for each tube based upon whether tubes are naturally replenished or depleted and how often the tube is used for change. It will always try and have at least 7 coins in any tube to ensure the exact change indication is kept off, then add more coins to the tubes until the overall value for the entire cassette matches the target value set by the customer.

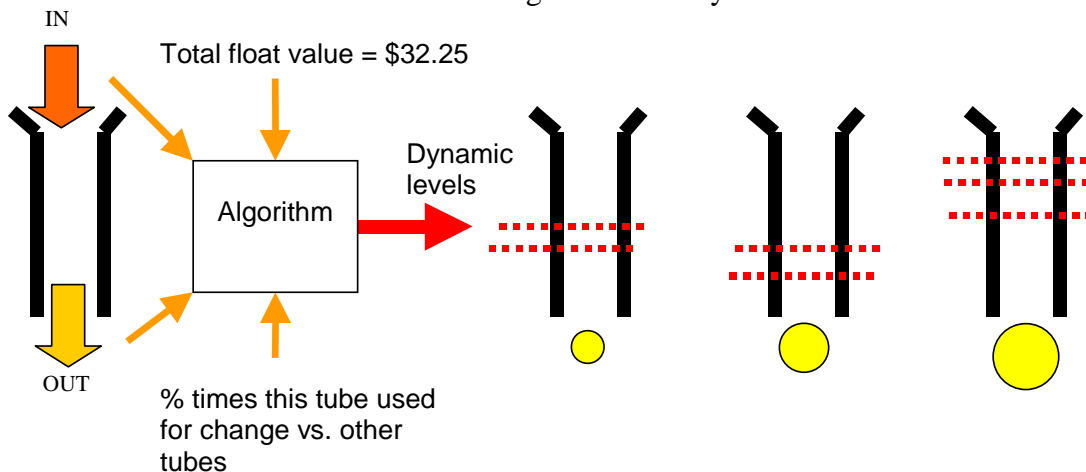

Will it work immediately?

Yes, however the initial mix of coins in the tubes may be non optimal

How do you set it up?

Use the keypad and screen to enable this function by:

Set the float style

- Press **Menu**
- Press **Setup**
- Press **abc**
- Scroll to the item "Float options" then press **Select**
- Scroll to the item "Select style" then press **Select**
- Press **Edit**
- Use the up or down keys to alter the setting to "Float to value" then press **OK**

Set the float value

- Scroll to the item "Float value" then press **Select**
- Press **Edit**
- Use the up/down/left/right keys to alter the value
- Press **OK**

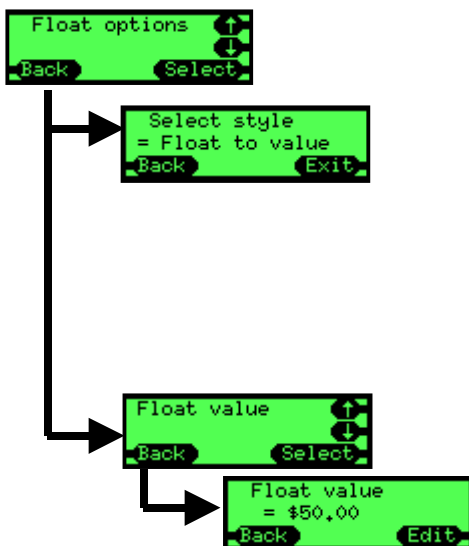

How to Section

How to use snapshot float

Symptom: Want to set float levels to current cassette condition

Cause : Float not setup as required

Fix: Use snapshot float by following this procedure

The snapshot feature works regardless of the float style (to level or to value, not applicable to auto). When this function is triggered it takes a “snapshot” of the current cassette and uses that to setup the float settings.

If required fill the cassette with the required amount of coins.

- This maybe a specific mix of coins e.g. 30 x 5c, 20 x 10c, 10 x 20c
- Or so each tube is filled so the top of all the coins are at the same level
- Or the overall value of the cassette holds €20.00

To take a snapshot follow these steps:

- Press **menu**
- Press **float**
- Press **snapshot**

If operating in “float to level” the screen will show the current levels in the tubes

If you wish to adjust a value then

- press the **adj** key
- use the **up/down** keys to select the required tube
- press **Edit**
- use the **up** and **down** keys to alter the value
- press **OK**
- when all coin tube values have been updated (if required) press **Done**

- If the displayed values for float are acceptable then press **Accept**

If operating in “float to value” the screen will display the total value of coins currently in the cassette

- This value can be adjusted by pressing the **adj** key in a similar manner
- When the required value is displayed press **Accept**

How to Section

How to select a payout algorithm

Symptom: Changer does not payout coins using required mix
Cause : Incorrect payout algorithm being used
Fix: Configure changer to use desired algorithm

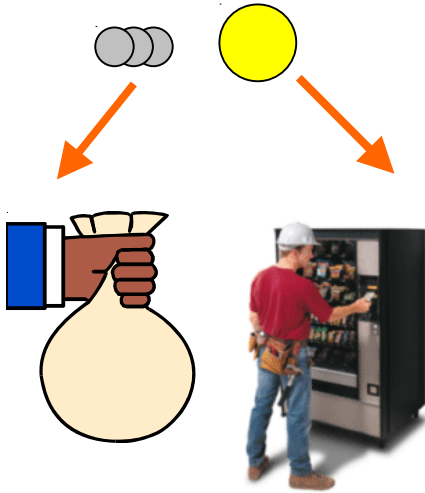

There are three payout algorithms in the Cashflow 7000 Series changer to improve the performance when used for particular tasks.

- **Big coins**
- **Small coins**
- **Change machine**

Big Coins (Best for Customer)

This is the default payout mix, use this if you want the fewest number of coins paid back to the customer. Hence these will typically be large value coins. This is sometimes referred to as a least coins algorithm

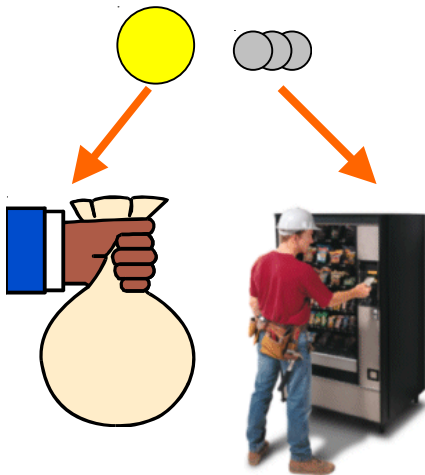

Small Coins (Best for Operator)

This simplifies the operation of counting coins in the cashbox for the routeman/counting room by having less quantity but higher value coins in the cashbox, as a result the customer may get a few extra small coins as change. This payout mix aims to leave the changer with space (10%) in the lowest two coin tubes for coins to be routed to rather than go to cashbox.

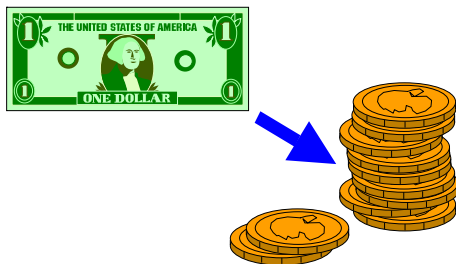

Change Machine

This is intended for applications where a dedicated change machine that converts bills to coins has been removed from the site and the remaining vending machines are setup to operate in a replacement capacity. The changer will try and payout one coin of each type, to give a mix of coins then pay any remaining value using the big coins algorithm.

All payout algorithms may be affected by the amount of change coins available, as typically they will try and stop a tube depleting to very low levels and use non preferred coins for payout instead.

How to Section

How to audit bill information on an MDB changer

Symptom: No bill audit information in the changer

Cause : Bill validator connected between changer and MDB machine

Fix: Connect the bill validator to the MDB peripheral loom on the changer as described

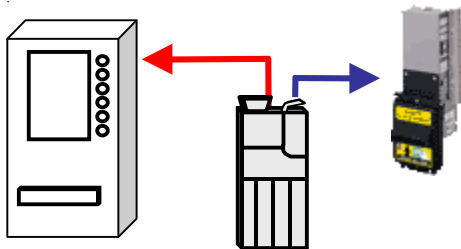

Connect the changer's MDB loom to the MDB loom on the vending machine (shown in red).

If one is not fitted then fit an MDB peripheral loom to the changer.

Connect the MDB peripheral loom from the changer to the MDB loom of the bill validator (shown in blue).

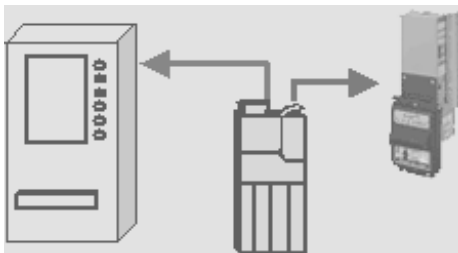

Power on the changer. The changer will listen to messages between the vending machine and the bill validator and audit any bills that are accepted.

```
Value of bills
accepted = $1
Exit      Pause
```

The audit value that records the non resettable value of bills accepted can be accessed on the display by pressing the yellow mode key twice in quick succession (**menu** then **audit**). When a validator is attached then this extra screen of information will be shown.

The audit data can be collected via the Ir port (or a DEX terminal if a DEX lead is fitted). Bill data will be logged in the **bold** fields in the audit data.

DEX Data Extract

```
DXS*9252131001*VA*V1/6*1
...
CA3*100*0*0*1*615*100*415*1
...
CA14*100*1*1*1*1
...
DXE*1*1
```

DEX field descriptions

CA301 = value of cash (coins and bills) in (interim)
 CA304 = value of bills accepted (interim)
 CA305 = value of cash (coins and bills) in (total)
 CA308 = value of bills accepted (total)
 CA1401 = bill value e.g. 100 for a \$1 bill
 CA1402 = number of this bill type accepted (interim)
 CA1403 = number of this bill type stacked (interim)
 CA1404 = number of this bill type accepted (total)
 CA1405 = number of this bill type stacked (total)

How to Section

How to setup tokens

Symptom: Doesn't accept tokens

Cause : Tokens not taught or setup correctly in the changer

Fix: Teach and configure tokens as described

CF7512 can have upto 6 tokens taught in the field.

Press **menu** then **setup** then **abc** then scroll to the “Coin cfg” menu then press **select**. At the “Token Teach” menu press **select**. Slots 27 to 32 are reserved for the 6 tokens that can be taught. Select the required slot, typically an empty or unused one then press **OK**.

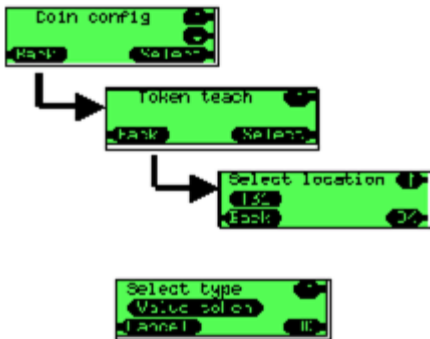

Select the type of token you are about to teach:

- **Value token** - a token that has a value (similar in use to a coin but tokens are routed to the cashbox only), you will be prompted later to enter a value for this token.
- **Vend token** - where the vending machine will typically give a free vend (this will vary from machine to machine)
- **Reject token** - this operates exactly like a free vend token but it is returned directly to the customer
- **Slug** - a fraudulent object that will be rejected
- **Delete** - this will delete data for the existing token in this slot

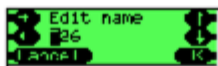

You can now alter the name that will be displayed when the token is finally set-up, by default it will be named “T” followed by the slot number e.g. **T26**. Use the cursor keys to alter the name then press **OK**

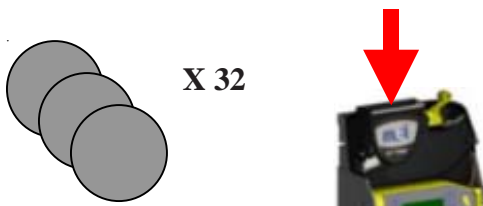

You will now be prompted to insert 32 samples of the token. Although you do not need to drop 32 the changer will perform significantly better if you drop as many as you can. You should not drop the same token repeatedly but use a collection of tokens of the same type.



When 32 tokens have been dropped a screen will be displayed, simply press the **finish** key.

The screen will then go to the beginning ready for another token type to be taught, if you have no more to teach then press the **back** key repeatedly to quit the menu.



Finally test that the tokens and all coins are accepted.

Frequently Asked Questions (FAQs)

How is MEI CASHFLOW™ 7000 different from other coin changers?

Simply put, MEI CASHFLOW™ 7000 is simple to use, yet very sophisticated in how it helps to manage change and information.

This product is a whole new breed of coin manager with improved features over other models. The combination of all these features resulted in the creation of a brand new tool that will increase your profitability and efficiencies, and make your life easier. The true breakthrough is how it will do the work for you without your constant intervention.

How does MEI CASHFLOW™ 7000 increase the operators' bottom-line?

By providing a better mix and more available change, better pricing options, bill flexibility, higher reliability and security, self reporting of lost sales and increasing account retention/customer satisfaction.

Drives Higher Sales:

1. Virtually eliminates exact change situations
2. Handles high value bills – \$10 and \$20 bills
3. Provides true price flexibility
4. Less down time – water resistant, jam resistant, more reliable
5. Reduces service call since drivers can fix most issues

Lowers Costs:

1. Accountability for all money, even cash in tubes
2. Provides instant paring
3. Drivers can resolve all jams, without tools
4. Virtually no training needed
5. Stores the least amount change necessary and prevents exact change issues
6. Reports on how well your team is doing.
7. Driver can alter the tubes by changing the cassette or the tubes

What does exact change really cost?

Most operators know it's a problem, believe current prices are correct or perceive the value of lost sales is insignificant. MEI CASHFLOW series 7000 shows you the true picture by individual vending machine.

MEI CASHFLOW series 7000 measures the selling rate when change is available and the selling rate when change is either unavailable or low. Then computes the percent of time the problem has occurred and the annualized value of not having enough change. For the first time management has the data from their own locations to show if exact change is truly a problem.

How does it eliminate exact change?

Through change optimization, complete and easy tube replenishment and highest tube capacity.

Change Optimization – MEI studied change algorithms and found many in traditional coin acceptors make poor use of change.

Frequently Asked Questions (FAQs) - Continued

For example, a 70¢ item purchased with a \$1 bill can:

- § payout three dimes
- § quarter/nickel combinations (even when the dime tube is full)
- § If the nickel tube is quickly emptied the machine is unnecessarily put into exact change for all other combinations.

The MEI CASHFLOW Series 7000 change override computes the coins to be paid and uses all combinations to stretch the available coins as far as possible. This feature prevents certain prices from starving the machine of change and allows the machine to have ample change.

Industry's only Five Tube Changer with Complete Tube Replenishment – Each tube can be replenished with the coins coming in from consumers. Coins are not diverted to the cashbox if space is available for that denomination.

Easy Replenishment –The driver can easily refill the change tubes.

- § The three tube openings are the largest available – so the driver can pour in an entire roll of change without even touching the mechanism.
- § A removable cassette can be refilled at leisure, and has an L-shaped base to prevent toppling.
- § The mechanism has a hook to hold the cassette in a completely accessible position. The driver does not need a flat surface for the cassette and won't need to hold open a flap with one hand while trying to hold the change bag, get out change and put into a narrow slot.

Highest Tube Capacity – MEI CASHFLOW series 7000 tubes hold more than the competition. MEI has five tubes, each with a height of 6 ¼ inches of coins (159mm). The total capacity of all tubes is 31¼ inches change. The MEI capacity for one is like having an extra “invisible tube” of capacity compared to competition.

Compare to the a five-tube competition with 5 3/8ths inches (136mm) tubes for a total of 26¾ inches. Another four-tube competitor has space for only 5 ¾ inches (148mm) of coins in a tube to its tube full sensor giving it a total replenishable capacity of less than 23 ½ inches.

What that means is that the MEI CASHFLOW series 7000 holds approximately 17% - 33% more volume in coins than its competitors' models.

How does the MEI CASHFLOW Series 7000 provide true price flexibility?

Stronger Location Negotiations – When negotiating to win a location the vend price can be the most important consideration. But, certain prices cause change problems unless there is a change machine on the same floor or in the same break room. Isolated machines run into exact change problems when moving off a quarter multiple. Even dropping the vend price from 75¢ to 70¢ can trigger untenable service calls to keep the machine's change replenished. The “exact change prevention” capabilities in MEI CASHFLOW Series 7000 allow the operator to negotiate without this constraint.

Maximize Specific Price Contracts – Certain customer contracts allowing pricing at or below 95¢. In many cases, so many consumers are inserting dollars that the available price cannot be used. This means

Frequently Asked Questions (FAQs) - Continued

a lower price of 75¢ or 85¢ is the highest that can be supported without being buried in service cost to top off a changer. (Industry average cost of service calls is \$50.) The flexible tube configuration, larger capacity and coin recycling enable better change management to support these price points.

Flexible Tubes to Optimize Payout – The cassette can have its tube reconfigured without using tools. They are simply unsnapped and the desired new configuration snapped in.

How does it handle high value bills, not just \$5 bills but \$10 and \$20 bills?

The unit allows the largest number of big diameter coins. Up to three, dollar tubes and a nickel tube can be used. The changer can hold over \$320 for making change. The unique L-shape cassette eliminates the constraint that all tubes must fit in a straight row across the front of the changer. Allowing MEI CASHFLOW series 7000 to handle truly large bills \$10s and \$20s that used to need a their own change machine.

What makes it water resistant, jam resistant and more reliable?

The unit meets MEI Gold Standard for Water Resistance. The MEI CASHFLOW series 7000 is designed to take abuse from vandals squirting water in openings, outdoor machines with leaky seals and drivers filling machines in the rain. The MEI CASHFLOW series 7000 will stay in service and prevent “jackpotting,” and shorted boards.

MEI engineers reviewed the existing market base for the problems experienced by operators. Not just MEI products, but all products. Iffy dispensing, coin jams, clearing out debris, off home dispensers and dozens of other potential weak points have been researched and solved by eliminating them from the design. For instance the lid opens wider. And, the dispenser has more than double the old power meaning sticky and gritty coins are no longer an issue. For example, weak areas have been reinforced making them tougher.

How does it reduce downtime and service calls?

Now the location staff or the route driver can fix the issues without leaving the machine down until the repairman can be scheduled. The unit is designed to allow sticky bits of paper, match boxes, etc. to be easily cleared without tools by the route driver.

Exact change is finally flagged. Exact change frustrates your customers, but on most machines there is no indication to the driver that there is a problem. It is left for him to “discover” one or more key tubes are short. Not a clear process for changers with opaque tubes. Finally, exact change triggers a warning, just like poor acceptance or dirt, with a warning light that is clearly visible.

How does MEI CASHFLOW Series 7000 provide accountability of all money, even cash in tubes?

Sonar zeros in on tube cash. No matter how the tubes are filled to what point, the level sensing sonar “reads it.” A single number is posted on the LCD display to show the total of all tubes. No eyeball readings, no hand calculations, just a single number. Less labor, less ambiguity.

All of the money. Bills stacked, coins to cash box, coins in the tubes, all are measured. Again by reporting a single number. If the tubes are replenished from traditional cash bag (take out a roll of dimes and take

Frequently Asked Questions (FAQs) - Continued

back five ones) then without special notes or accounting, the money will be tracked. The total in the cash bag will be the same (like value for like value) **and** the total net in the mechanism will be the same too.

Less temptation. Maintaining tight accountability with minimal effort also reduces the time spent on investigating and documenting cash irregularities.

What is the cash capacity of the tubes?

The tubes will hold up to \$343 in US coins. A typical set up would hold \$305.

How accurate is the sonar technology?

The sonar sensing is accurate +/- 2 coins. In approximately 0.2% (1 in 500), there could be a “fluke” where accuracy is compromised. But upon the next sonar reading, the accuracy is again at the expected high level.

How can my drivers attain instant paring?

MEI CASHFLOW series 7000 does all the work. The simplest accountability is to fill the machine with product (to its planned level) and to replenish the tubes in the changer to their planned levels. Paring the changer used to involve dumping out surplus coins and refilling the denominations that are not at their levels.

Now with MEI CASHFLOW series 7000’s advanced processor, the LCD display and the sonar system in the changer do most of the work. With the push of the par button, surplus coins are automatically dispensed. (And, if dispensing is too rapid, there is a pause button.) The display lists any denominations that are short and by how much.

MEI CASHFLOW series 7000 makes paring simpler, faster and more accurate.

Can my drivers manage service calls without tools?

Drivers call fix all jams and save two calls. Having all coin paths accessible without tools, and eliminating special repair training fix saves the cost of the repair call – typically \$50. As mentioned earlier it also makes money by brining the machine back to operation sooner. That is the second saving.

Driver can alter the tubes by changing the cassette or the tubes. As prices change or machines relocate, what is an ideal tube configuration may be suddenly be inappropriate. Both options for changing tubes are available in the MEI CASHFLOW 7000. Swap tubes individually by just snapping them in and out. Or, change out the entire cassette. In both situations the LCD display walks you through each step.

How much training is required?

Almost no training is needed, operations are very simple.

The “Smart” Display Menu Tells All. Similar to a cell phone, the display presents simple menus that list what is available and guide the driver though what to do. And, if desired, choose from up to 8 languages including Spanish and French.

Frequently Asked Questions (FAQs) - Continued

Service versus Replenish. Should you want to restrict what the drivers can change, the controls are build in. Paring or changing the tubes is available to everyone. However, changing par levels and change-making modes are restricted with a password.

How do I eliminate excess change in my tubes?

Every Coin Must Earn Its Keep. With MEI CASHFLOW 7000 only the least amount of change necessary is stored. The *automatic par* mode computes how many of each denomination is needed to prevent an exact change occurrence. This is the number of coins retained, not one extra. Automatic float customizes the change retained so it is best for that specific location.

Will the changer dispense to zero coin inventory?

Yes.

How can I tell how well my team is managing the equipment?

Last month statistics – provides reports to supervisors on how much time was spent in exact change mode, the value of lost sales and which tubes were replenished. This information can be used to improve driver training and provide objective feedback.

How will I restrict access to changer information?

You can set a code on the mechanism such that a supervisor can restrict access to sensitive soft option features. Drivers will however have access to audit data – as they should.

What is the life of a changer?

MEI CASHFLOW series 7000 has a projected 12-year design life, which is twice that of the competitors. And, an anticipated 20-year physical life.

Does MEI offer a trade-in upgrade program? - No

Can I get training for my technicians?

While downtime and repairs are minimal, route drivers can manage many required repairs during servicing. Drivers have true jam detection through the LCD diagnostics. MEI CASHFLOW series 7000 is very intuitive and requires practically no training. Most drivers who use a cell phone will find the LCD display very easy to navigate.

How will MEI CASHFLOW™ 7000 be serviced?

Service for MEI CASHFLOW series 7000 will be consistent with other MEI products. You may contact your MEI Authorized Service Center (ASC), just as you do with your other MEI products.

Do all tubes self fill?

Yes.

Can we just buy “tubes” to change the cassette?

Yes.

Frequently Asked Questions (FAQs) - Continued

Can we get labels to identify the tubes?

Yes, this is planned to be available for the launch date.

Are there limitations on the tube configurations?

The only restrictions are; no dollar tube in A or B-positions, no quarter tube in B-position, no dime tube in E-position.

Can you teach the changer in the field?

In the field, you can “teach” tokens and program coins.

What is the warranty on the MEI CASHFLOW series 7000?

The standard warranty period is 2 years, or the same as your current customer agreement.

Who should I contact with questions about MEI products?

Your first line of contact is your MEI sales representative. For additional questions, you may contact the MEI customer service team, at 1-800-345-8215.

How do I reach the technical support call center?

The technical support number is staff by industry-specific technical field representatives and can be reached by calling 800-345-8215.

CF7512i Exploded Views

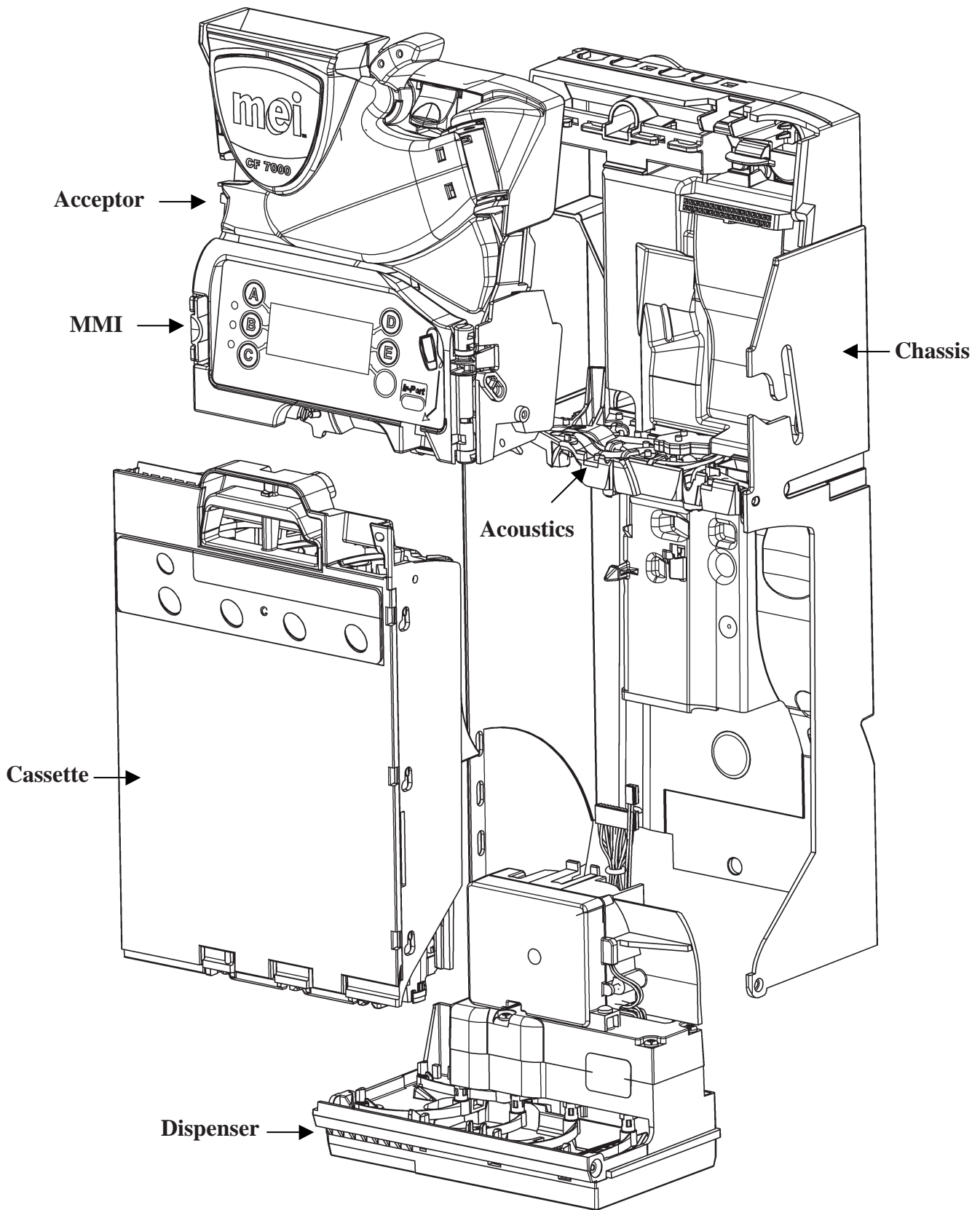

CF7512i Acceptor

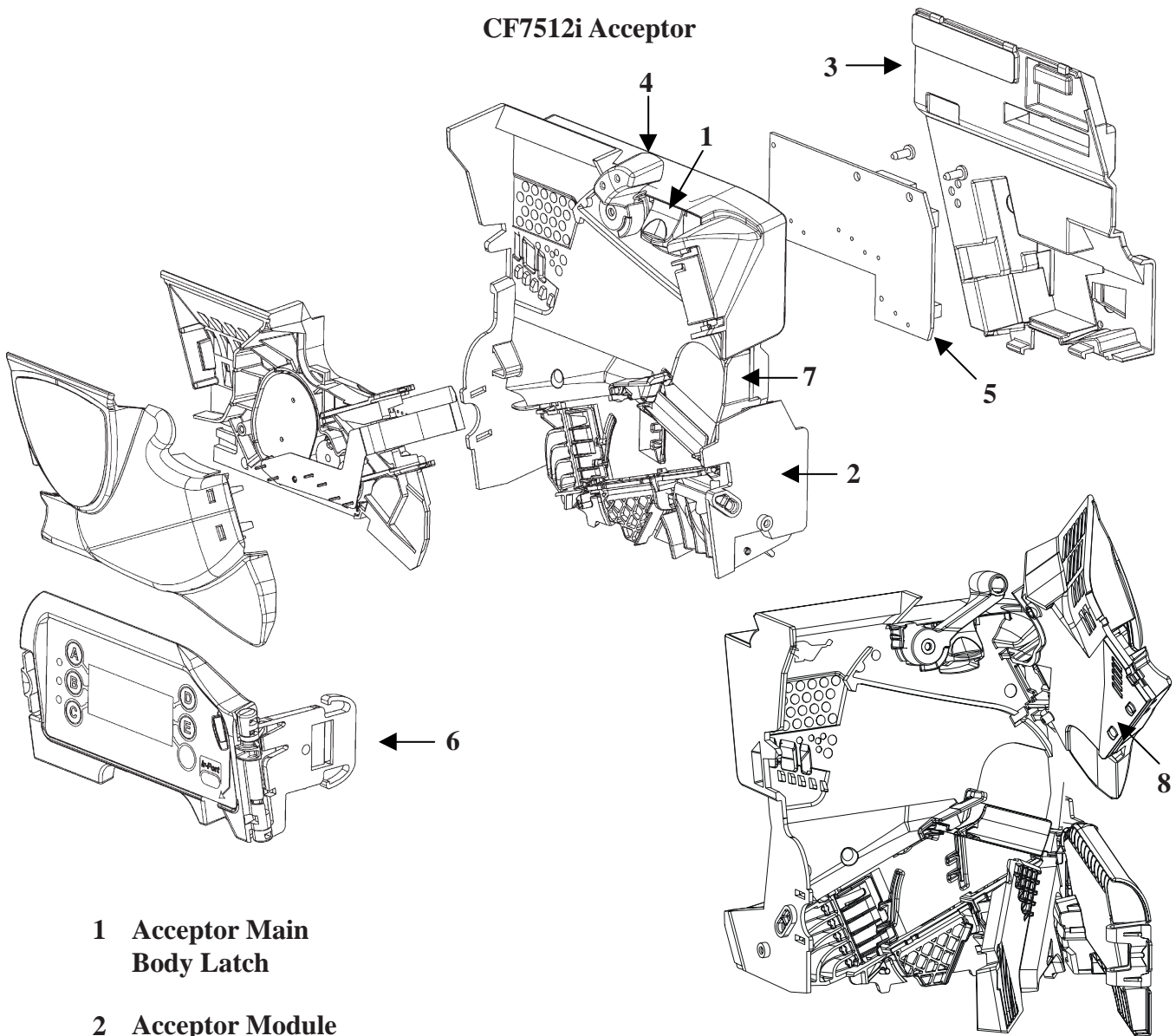

- 1 Acceptor Main Body Latch**
- 2 Acceptor Module**
- 3 Acceptor Sensor Cover**
- 4 Reject Lever**
- 5 Interface Control Board**
- 6 MMI / LCD Assembly**
- 7 End Snubber**
- 8 Ramp Snubber**

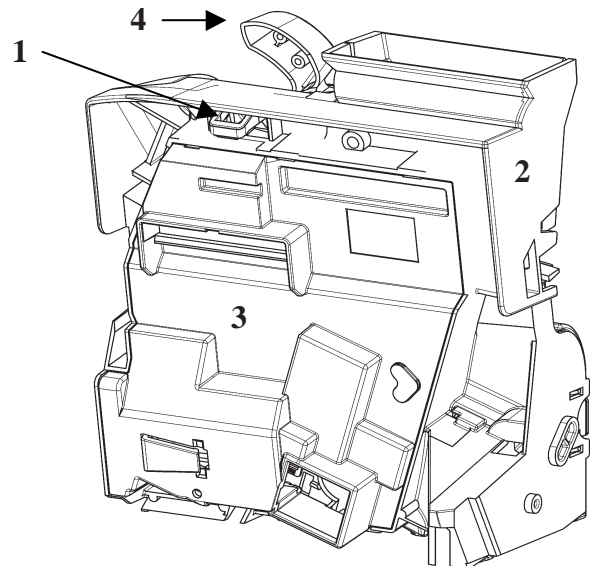

1 Chassis

2 Acoustic Manifold

3 Upper Control Board Cover

4 Lower Control Board Cover

5 Dispenser Assembly

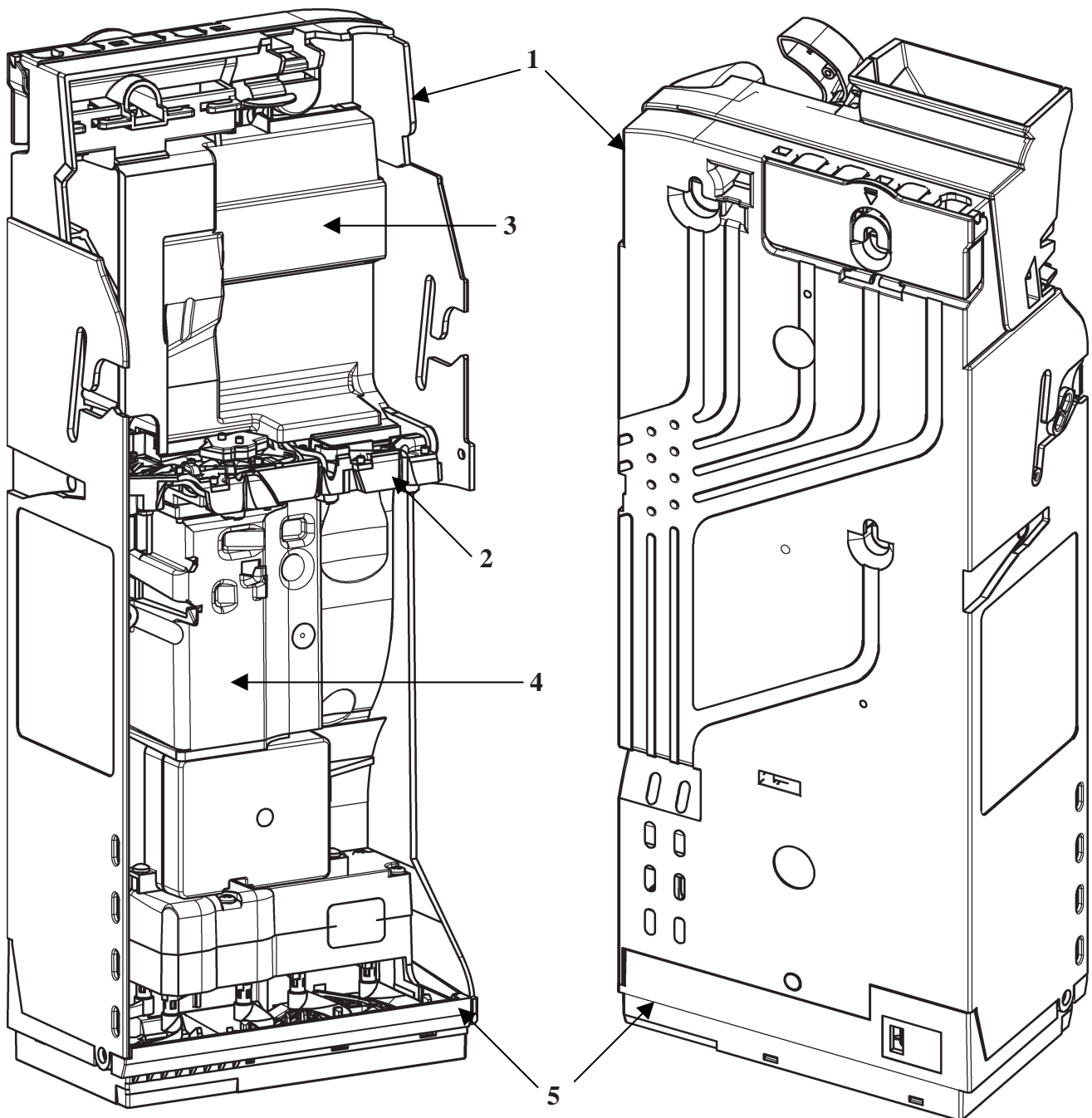

CF7512i Cassette

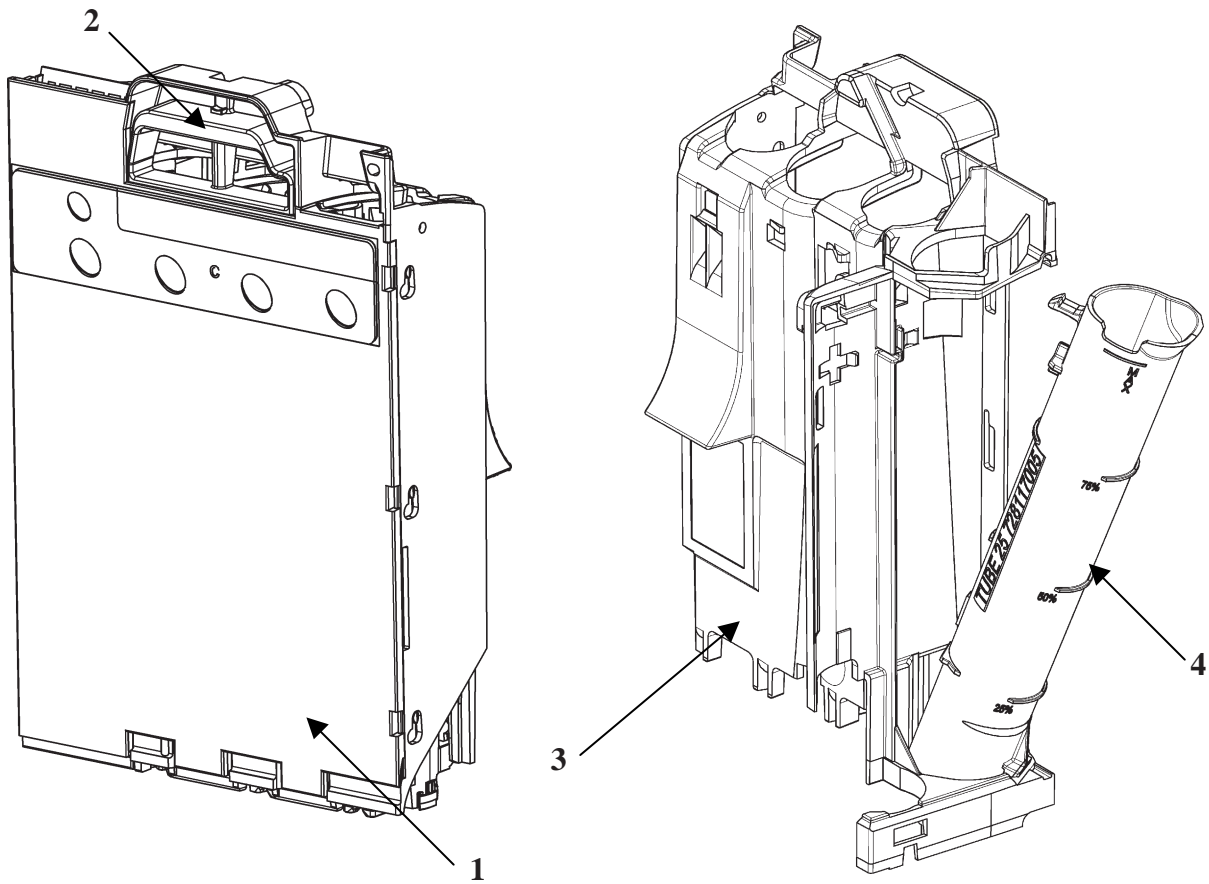

1 Cassette Cover

2 Cassette Release Latch

3 Cassette Skeleton

4 Coin Tubes

CF7512i Dispenser

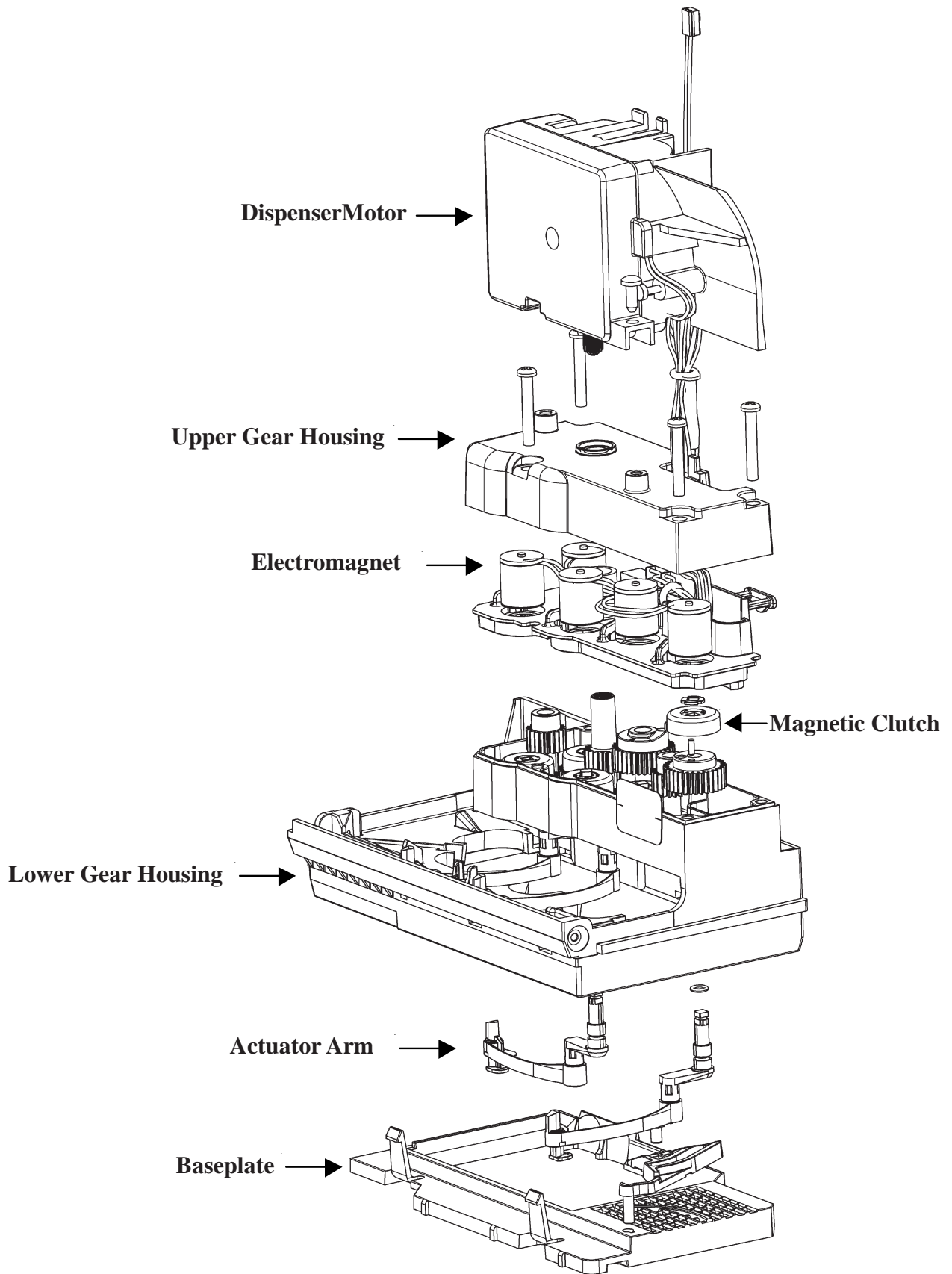

CF7512i Dimensions

Front View

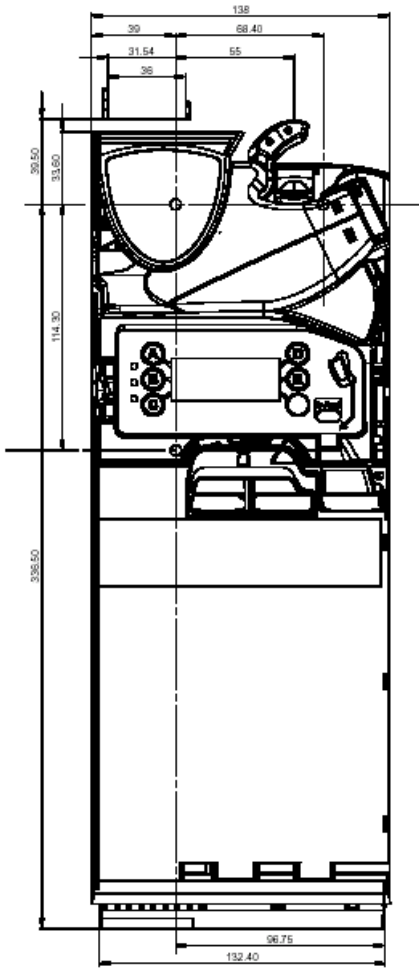

Side View

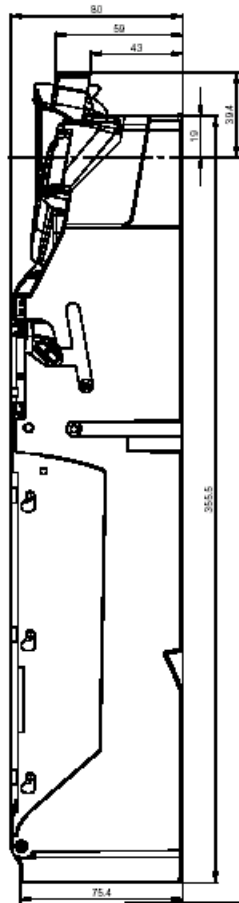

Bottom View

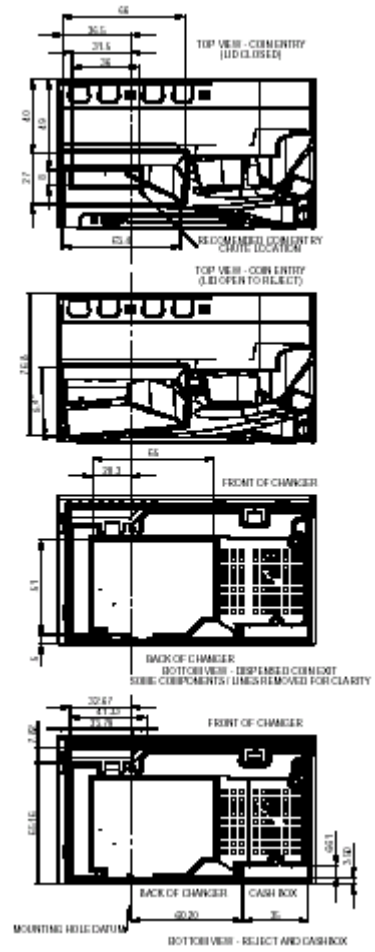

Top View

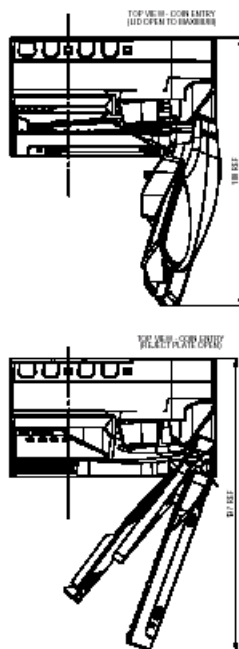

MEI

Technical Support 1(800)345-8172
Customer Support 1(800)345-8215
<http://www.meigroup.com>

