

CCM5G Series Coin Changer



Designed to simplify your business through reliable, field-proven performance.

Five-Tube Cassette

Greater capacity eliminates change starvation. Sell more product and avoid costly service calls.

Auto Cassette Programming

Cassettes snap into place and coin configurations are automatically recognized by the changer. No programming needed by service technician, no possibility of error. Optimize sales by interchanging cassettes according to vend price.

3-Coin Payout System

Simultaneous payout of three coins speeds transactions and increases throughput in high-volume locations.

Smart Payout

Unit makes multiple attempts to pay out coins if necessary, virtually ensuring transaction; results in fewer service calls.

Anti-Salting Channel

Unique diversion path protects changer and vendor from salt water vandalism and damage.

Memory Back-Up

Non-volatile memory ensures that changer will retain its settings and transaction history in case of a power failure.

No Tools Required

Designed for easy assembly/disassembly and maintenance, even at vend site.

Swing-Open Payout Base

Swing-open cassette base makes for easy collection and change replenishment. No tools required. Expedites cleaning and removal of foreign material.

Last Coin Payout

No dead inventory.

Warranty

Limited 2-year warranty.



**CCM5G Series
Five-Tube Changer**

Field Tested, Field Proven

Conlux . . . Simply the right choice

**Conlux ...
the MEI value brand of bill and
coin validator products.**

mei
www.meigroup.com

MEI is ISO 9001:2000 Certified



CCM5G Series Coin Changer



**Simple operation.
Maximum durability.**

CCM5G Specifications

Interface	Multi-Drop-Bus (M.D.B.)	
Operating Voltage	+34VDC	
Power Consumption	Standby 0.10A	
Operating State	Motor Operation 0.66A Peak Max. 5 sec. 0.92A	
Operating Temperature Range	5° F (-15° C) to 140° F (+60° C)	
Insulation Resistance	20M Ohm or more	
Weight	4.2 lbs. (1.9 Kg)	
Dimensions	HxWxD: 14.83" x 5.43" x 3.23" (376mm x 137mm x 82mm)	
Number of Motors	1 Motor - 15VDC	
Number of Solenoids	5 for Coin Selection - 15VDC	
Coin Acceptance	U.S.: 5¢, 10¢, 25¢, \$1 CAN: 5¢, 10¢, 25¢, \$1, \$2 Switch Selectable for U.S. only, Canadian only, or both	
Cassette Tube	US-1 Cassette: 1N, 1D, 3Q	PN 5030004030
	US-2 Cassette: 2N, 2D, 1Q	PN 5030004040
	US-4 Cassette: 1N, 1D, 2Q, \$1	PN 5030004050
	US-5 Cassette: 2N, 3D	PN 5030004060

"We have used Conlux coin mechs and validators since June of 2001. I have not come across another brand as reliable and inexpensive as Conlux. Even in the dirtiest conditions, you can count on Conlux to work every time. I would highly recommend their products to everyone in the vending industry."

Darryl Martin

Service Department Manager
D&S/Davians

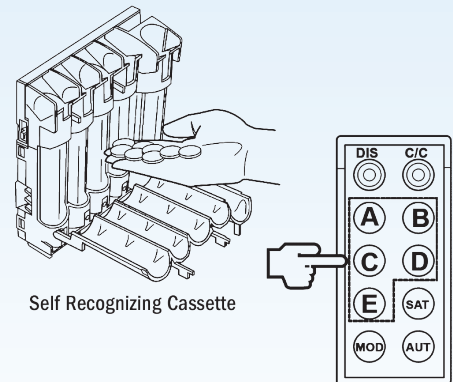
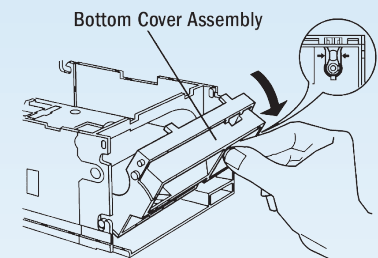

Simple Touch Pad
Inventory Panel

About the Conlux product line

Conlux is the MEI value brand of bill and coin validator products, acquired by MEI in 2003. The Conlux brand is the leading payment systems product in Japan, and has been distributed in North America since 1985. Established in Japan in 1967 to produce and sell coin mechanisms for vending machines, Conlux products are designed to simplify business through reliable, field-proven performance.

MEI Corporate Headquarters

1301 Wilson Drive
West Chester, Pennsylvania 19380
1-610-430-2700
1-800-345-8215



Mixed Sources
Cert no SW-COC-002607
© 1996 FSC

