

# **Hamilton Manufacturing Corp.**

---

1026 Hamilton Dr., Holland, OH 43528 • Phone: 419-867-4858 / 800-837-5561 • Fax: 419-867-4857 • [www.hamiltonmfg.com](http://www.hamiltonmfg.com)

## **DTT Installation Manual**

# CONTENTS

<b>I. INTRODUCTION</b> .....	<b>3</b>
<b>II. SPECIFICATIONS</b> .....	<b>4</b>
<b>DTT/DTI POWER REQUIREMENTS</b> .....	<b>5</b>
<b>CABINET DIMENSIONS (WITHOUT VALIDATOR)</b> .....	<b>6</b>
<b>CABINET DIMENSIONS (DTT-H)</b> .....	<b>7</b>
<b>CABINET DIMENSIONS (WITH VALIDATOR)</b> .....	<b>8</b>
<b>TIMER CONNECTION</b> .....	<b>9</b>
<b>III. INSTALLATION</b> .....	<b>10</b>
Unpacking .....	10
Cabinet installation .....	10
Without Validator: .....	10
With Validator: .....	14
<b>DTT WIRING</b> .....	<b>17</b>
<b>TERMINAL BLOCK CONNECTIONS</b> .....	<b>17</b>
<b>SWITCHED TIMER POWER</b> .....	<b>18</b>
<b>TIMER ACTIVATION INPUT</b> .....	<b>19</b>
<b>COIN CIRCUIT WIRING</b> .....	<b>20</b>
<b>MAIN HARNESS (48-3198)</b> .....	<b>21</b>
<b>HARNESS, DTT COINCO (48-3190)</b> .....	<b>22</b>
<b>HARNESS, DTT MARS (48-3191)</b> .....	<b>23</b>
<b>HARNESS, DTT CASHCODE (48-3192)</b> .....	<b>24</b>
<b>LIMITED WARRANTY AGREEMENT</b> .....	<b>25</b>

# **I. INTRODUCTION**

---

---

The DAN Transaction Terminal (DTT) is a product that allows the acceptance of high speed credit card and CVCs in applications that were once not available. The DTT can be configured with or without a Validator. Once properly installed the DTT will allow remote monitoring, auditing, and programming of the DTT.

Hamilton recommends consulting local codes before installing any equipment.

## **II. SPECIFICATIONS**

---

---

The Hamilton DTT is designed to be firmly mounted to a solid surface. Installation designs also call for the DTT to be hard piped using commercial conduit between the DTT and existing equipment. On the next 4 pages are diagrams of physical dimensions and call outs for the three cabinet types. Please study the diagrams to familiarize yourself with differences between the three cabinet styles.

## ***DTT/DTI POWER REQUIREMENTS***

<u>Controller Model</u>	<u>Components</u>	<u>Voltage</u>	<u>Current</u>
DTI	Controller Only	24VAC	1.0A
DTT	Controller Only	24VAC	1.0A
DTT - Mars	Controller	24VAC	1.0A
	Validator + Heater	24VAC	3.0A Isolated
DTT - Coinco	Controller	24VAC	1.0A
	Validator + Heater	24VAC	3.5A Isolated
DTT - Cashcode	Controller	24VAC	1.0A
	Validator + Heater	24VAC	3.0A Isolated

### **Warning**

**When operating a DTT with a Mars, Coinco, or Cashcode Validator, Hamilton requires a separate power source for the Validator. This source must be a 24VAC transformer power supply. The Validator MUST HAVE it's own source of power, a 24VAC Hot and a 24VAC COM.**

# CABINET DIMENSIONS (WITHOUT VALIDATOR) Discontinued 09/01/06

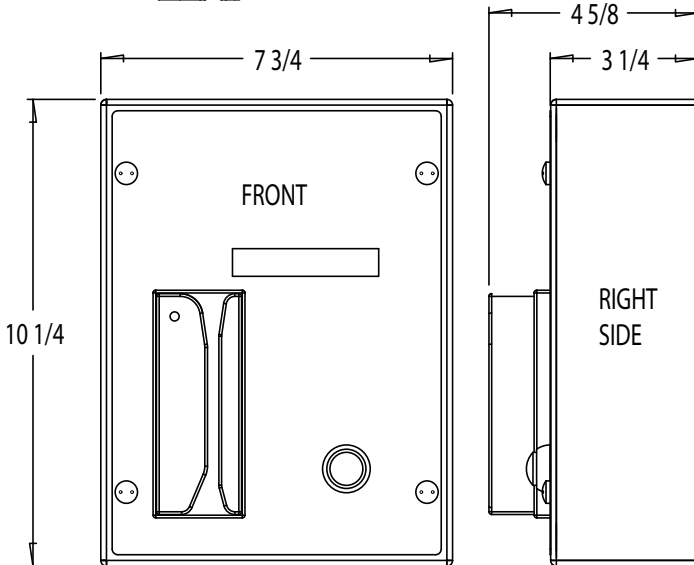
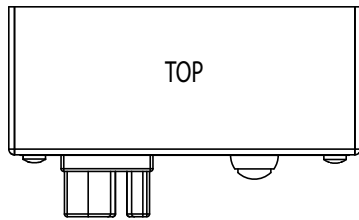
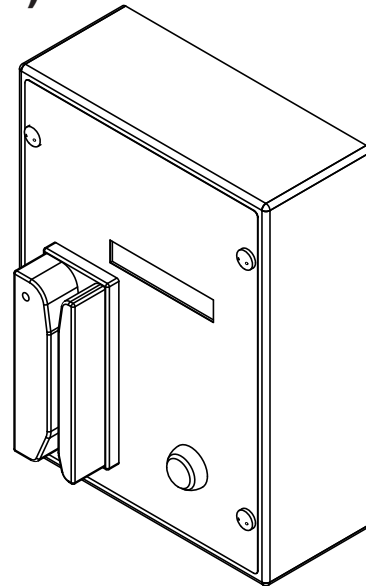

Ø1/2  
MOUNTING HOLE  
(4 PLCS)

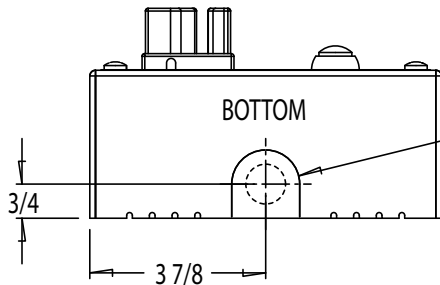
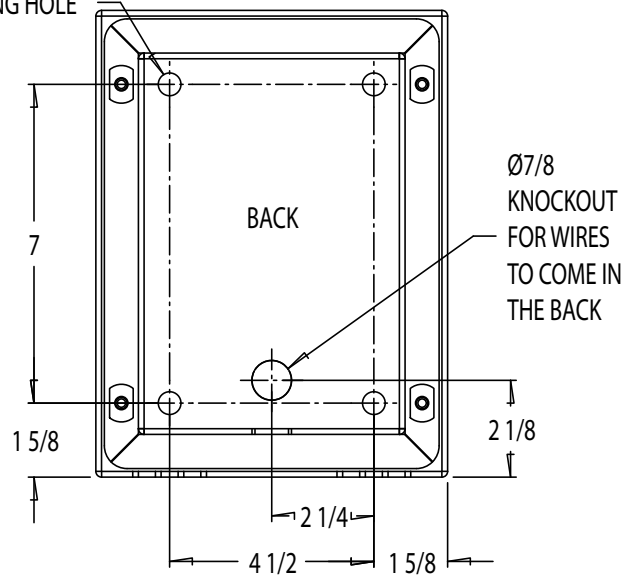

Ø1 1/2  
KNOCKOUT  
THAT COVERS  
A Ø7/8 KNOCKOUT  
FOR THE WIRES  
TO COME IN THE  
BOTTOM

# CABINET DIMENSIONS (DTT-H)

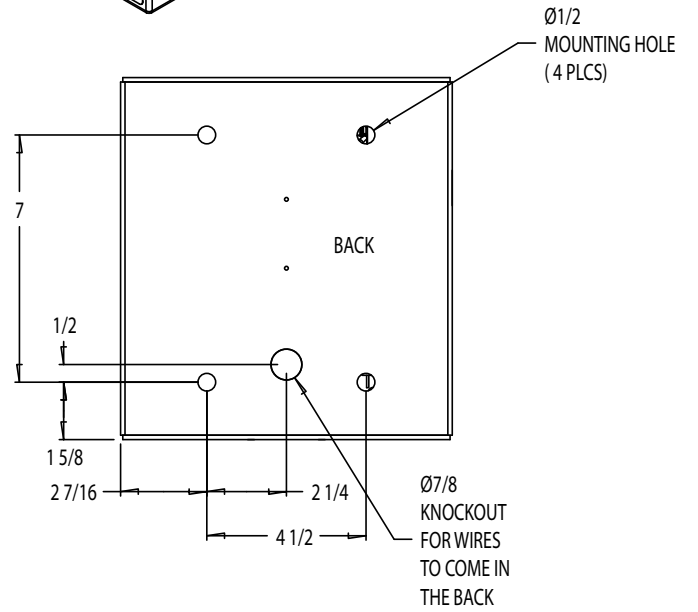
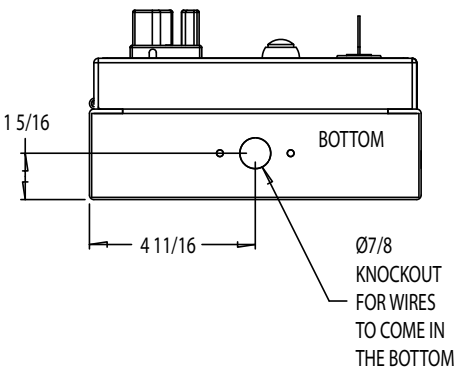
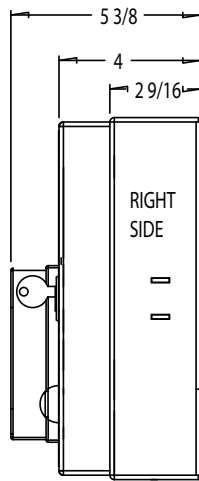
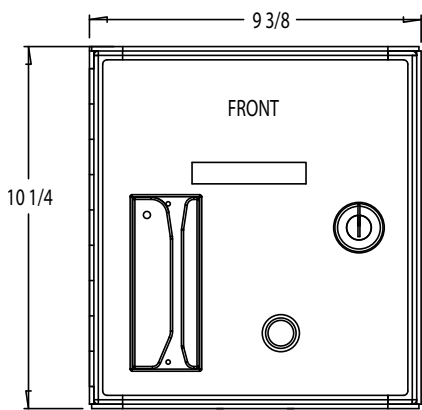
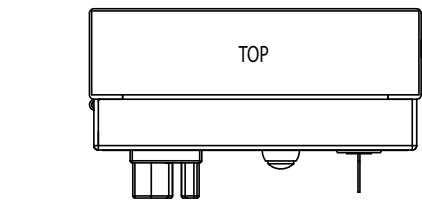
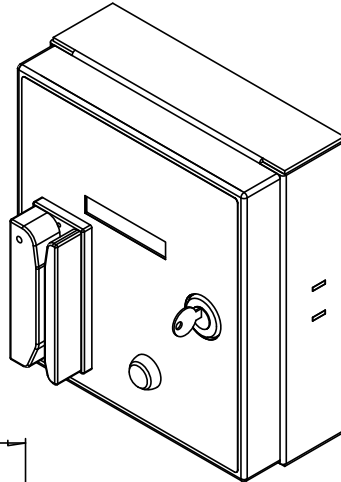

# CABINET DIMENSIONS (WITH VALIDATOR)

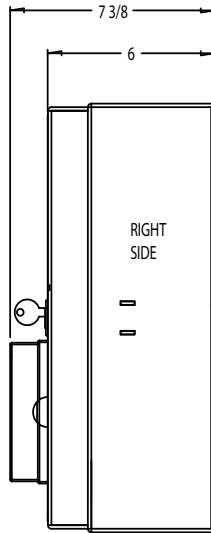
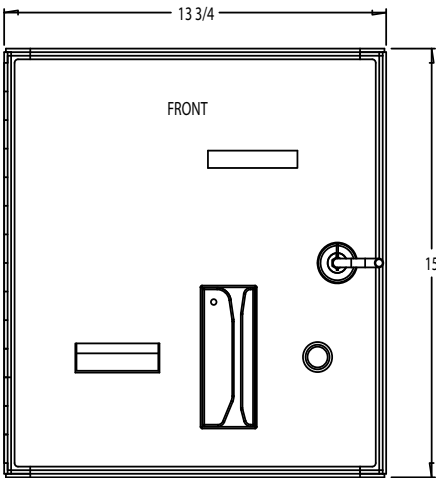
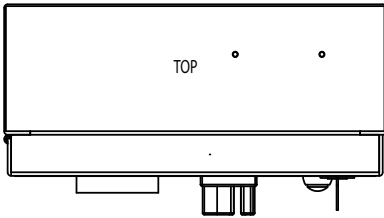
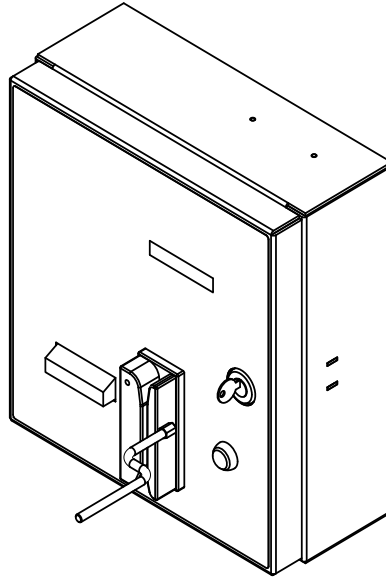

Ø1/2  
MOUNTING HOLE  
(4 PLCS)

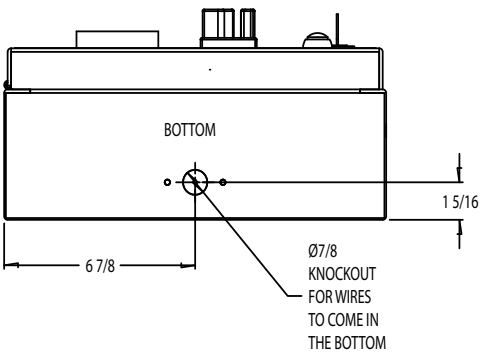
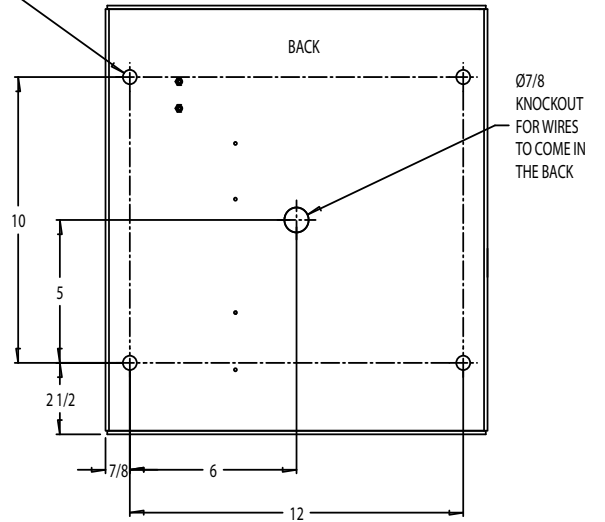



# TIMER CONNECTION

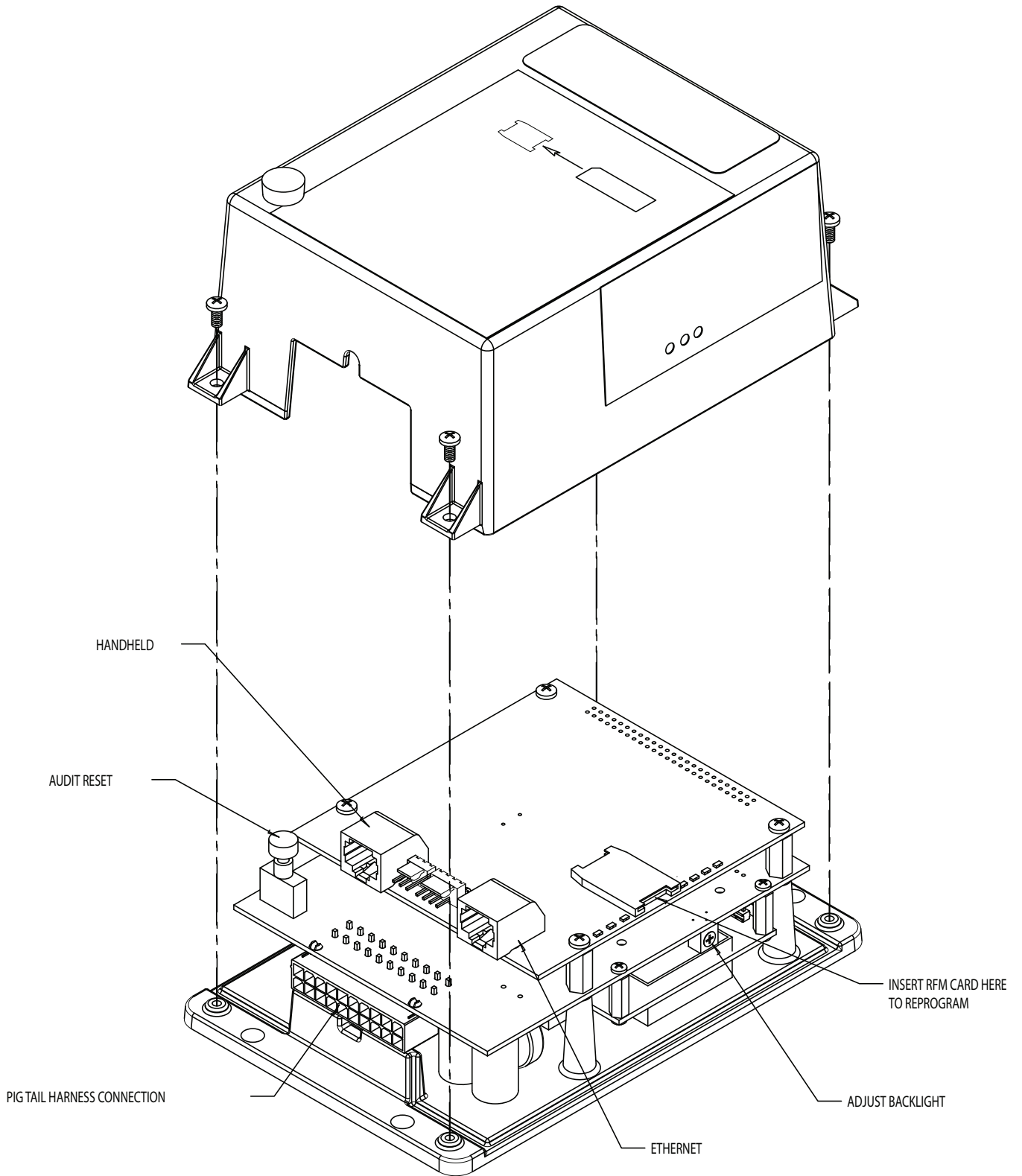

# III. INSTALLATION

---

---

## **Unpacking**

Be sure to save your key or security wrench.

The key to your new cabinet is placed inside a small cloth bag attached to the inside of the machine. When removing any packing materials be sure to locate the bag containing the key or wrench and set it aside so it does not get thrown out. Make a PERMANENT record of the number on your key in case it gets lost and must be reordered.

## **Cabinet installation**

### **Without Validator:**

- Disconnect all power routing to existing equipment.
- Using cabinet diagrams determine where to mount the DTT cabinet. Again be sure the selected location is solid.
- Attach the DTT cabinet back to selected surface. Follow all applicable local codes.
- Run commercial conduit between the DTT cabinet and existing equipment. Knock out desired opening in the cabinet to allow easy conduit installation.
- Pull five (5) wires from existing equipment to DTT.
- Using attached wiring schematic make all appropriate wire connections to the DTT pigtail. Wire nuts or other appropriate hardware shall be used. All unused wires in the DTT pigtail should be neatly arranged within the DTT cabinet.
- Make all appropriate wire connections inside existing equipment.
- Pull a CAT 5 cable from equipment room to DTT. The CAT 5 can be run within the same conduit.
- Without Hinge
  - Assemble a RJ-45 plug onto the end of the CAT5 cable.
  - Remove the back cover from the controller.
  - Attach the CAT5 plug into the correct RJ-45 receptacle. *See connection diagram (page 9).*
- With Hinge
  - Assemble a RJ-45 plug onto the end of the CAT5 cable.
  - Remove the back cover from the controller.
  - Attach the CAT5 plug into the network dataline suppressor.
- Restore power to existing equipment.
- Using handheld and programming manual program timer.
- Replace back cover onto controller.
- Attach DTT cabinet face to cabinet back using the four (4) provided #1/4-20 security bolts, or close and lock on the hinged cabinet.

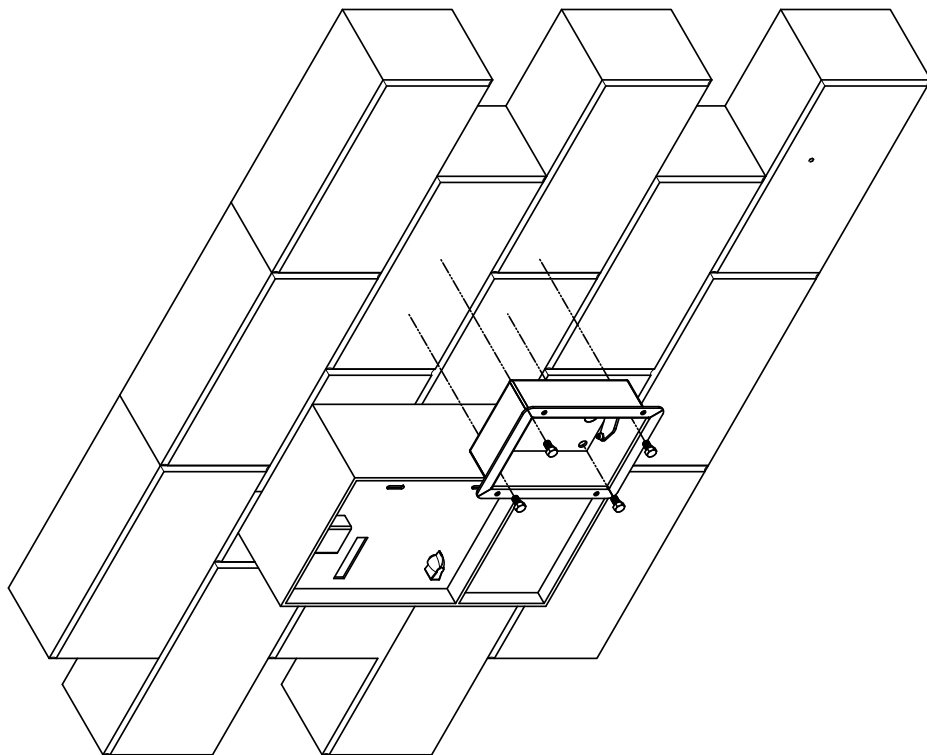
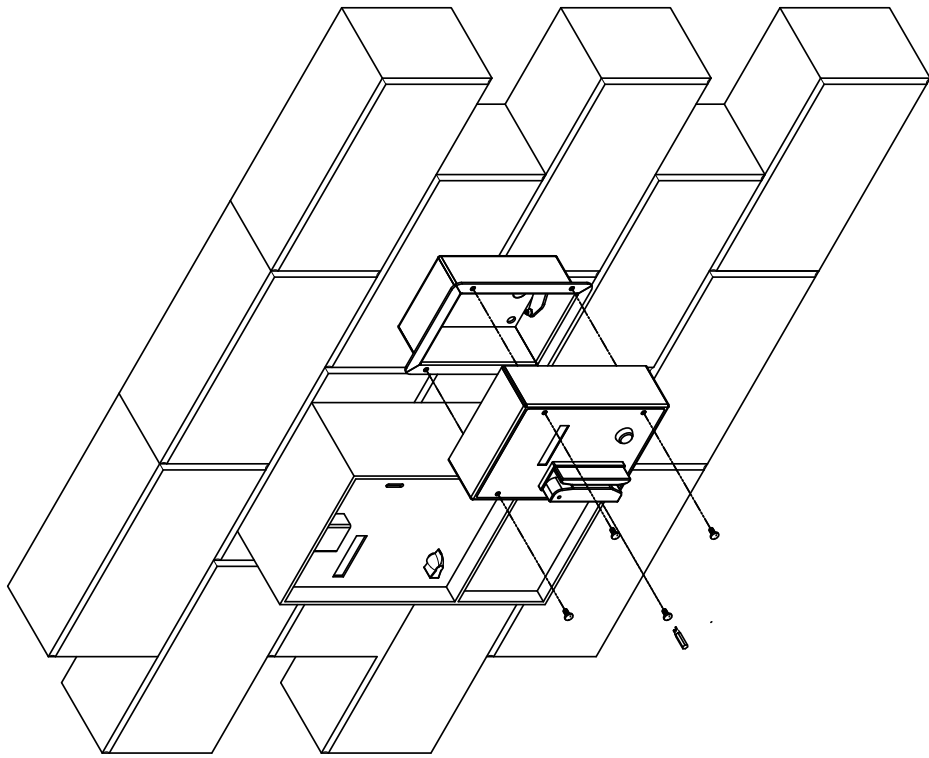

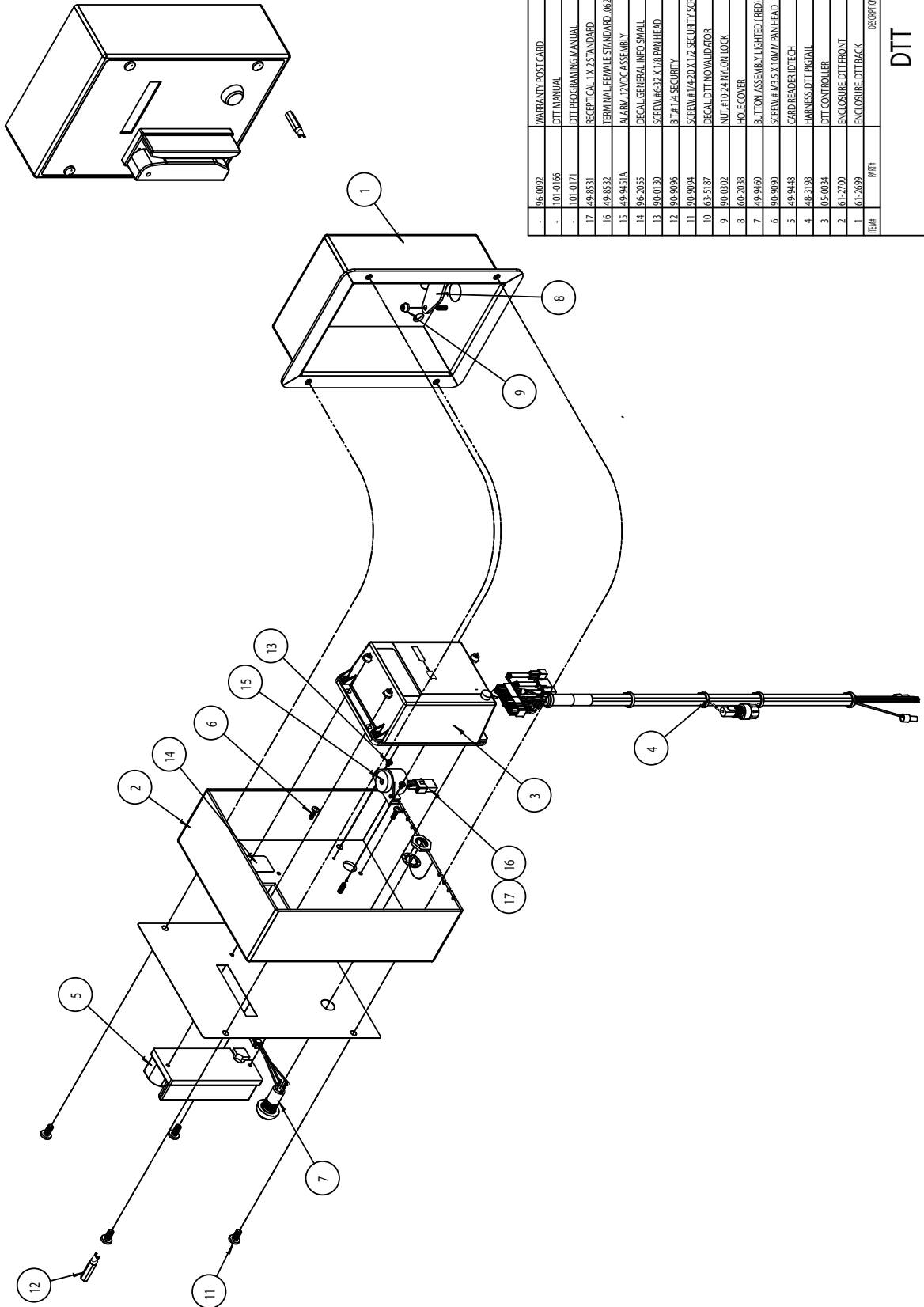

96-0092	WARRANTY POST CARD	1
-	DTT MANUAL	1
101-0166	DTT PROGRAMMING MANUAL	1
101-0171	RECEPTICAL TX STANDARD	1
49-8531	TERMINAL FEMALE STANDARD_062	2
49-8532	ALARM_12VDC ASSEMBLY	1
49-9451A	DECAL GENERAL INFO SMALL	1
96-2055	SCREW #6-32 X 1/8 PAN HEAD	2
90-0130	BIT #1/4 SECURITY	1
90-9096	SCREW #1/4-20 X 1/2 SECURITY SCREW	4
90-9094	DECAL DTT NO VALIDATOR	1
63-5187	NUT #10-24 NYLON LOCK	6
90-0802	HOLE COVER	1
60-2038	BUTTON ASSEMBLY (LIGHED I RED)	1
49-9460	SCREW #4-4 X 1.0MM PAN HEAD	2
90-9090	CARD HEADER ID TECH	1
49-9448	HARNESS DTT DIGITAL	1
48-3198	DTT CONTROLLER	1
05-0034	ENCLOSURE DTT FRONT	1
61-2700	ENCLOSURE DTT BACK	1
61-2699	DESCRIPTION	QTY
ITEM#	PART#	

DTT

-	1107	E-FACT POST CARD	1
-	101-0173	DTT INSTALLATION MANUAL	1
-	101-0171	DTT PROGRAMMING MANUAL	1
-	96-0082	WARRANTY POST CARD	1
33	90-9089	SELF-LOCK ADHESIVE BACKED TAB 1"x1"	2
32	48-3208	CABLE, 20' CAT 5 CABLE	1
31	49-1222	NETWORK DATA LINE SUPPRESSOR	1
30	96-2055	DECAL - GENERAL INFO SMALL	1
29	63-5191	DTT DISPLAY FILLER	1
28	47-0232	CLAMP CABLE RANDUIT	3
27	47-0275	CABLE TIE 6"	3
26	90-0130	SCREW #6-32 1/8" PH	2
25	60-2088	HOLE COVER	1
24	49-8532	TERMINAL FEMALE STANDARD	2
23	49-8531	RECEPTICAL 1X2 STANDARD	1
22	49-9451A	ALARM 12V DC ASSEMBLY	1
21	48-3198	HARNES DTT DIGITAL	1
20	90-0302	NUT # 10-24 NYLOCK	6
19	90-0612	WASHER #10 INTERNAL LOCK	2
18	90-0301	NUT #10-24 X 3/8" HEX	2
17	48-0051A	GROUND STRAP	1
16	47-3012	GASKET SPONGE RUBBER	3
15	63-5190	DECAL DTT HINGED NO VALIDATOR	1
14	90-9090	SCREW M3.5 X 10mm PH	2
13	49-9448	CARD READER ID TECH SURFACE MOUNT	1
12	49-9460	ASSEMBLY BUTTON LIGHTED (RED)	1
11	96-2077	DECAL DTT TERMINAL BLOCK	1
10	90-0032	SCREW # 6-32 X 3/8" PH	2
9	47-3192	TERMINAL BLOCK	1
8	05-0034	DTT CONTROLLER	1
7	90-0335	NUT #1/2-13 SQUARE	1
6	63-5040	LOCK CRANK	1
5	90-0275	LOCK BOLT #1/2-13 X 1"	1
4	90-0148	SCREW # 10-24 X 3/8" PH	1
3	61-2153	BRACKET DOOR LOCK	1
2	63-5001	LOCK SINGLE COMPLETE	1
1	61-2733	CABINET DTT HINGED NO VALIDATOR	1
ITEM#	QTY	DESCRIPTION	QTY

# DTT-H

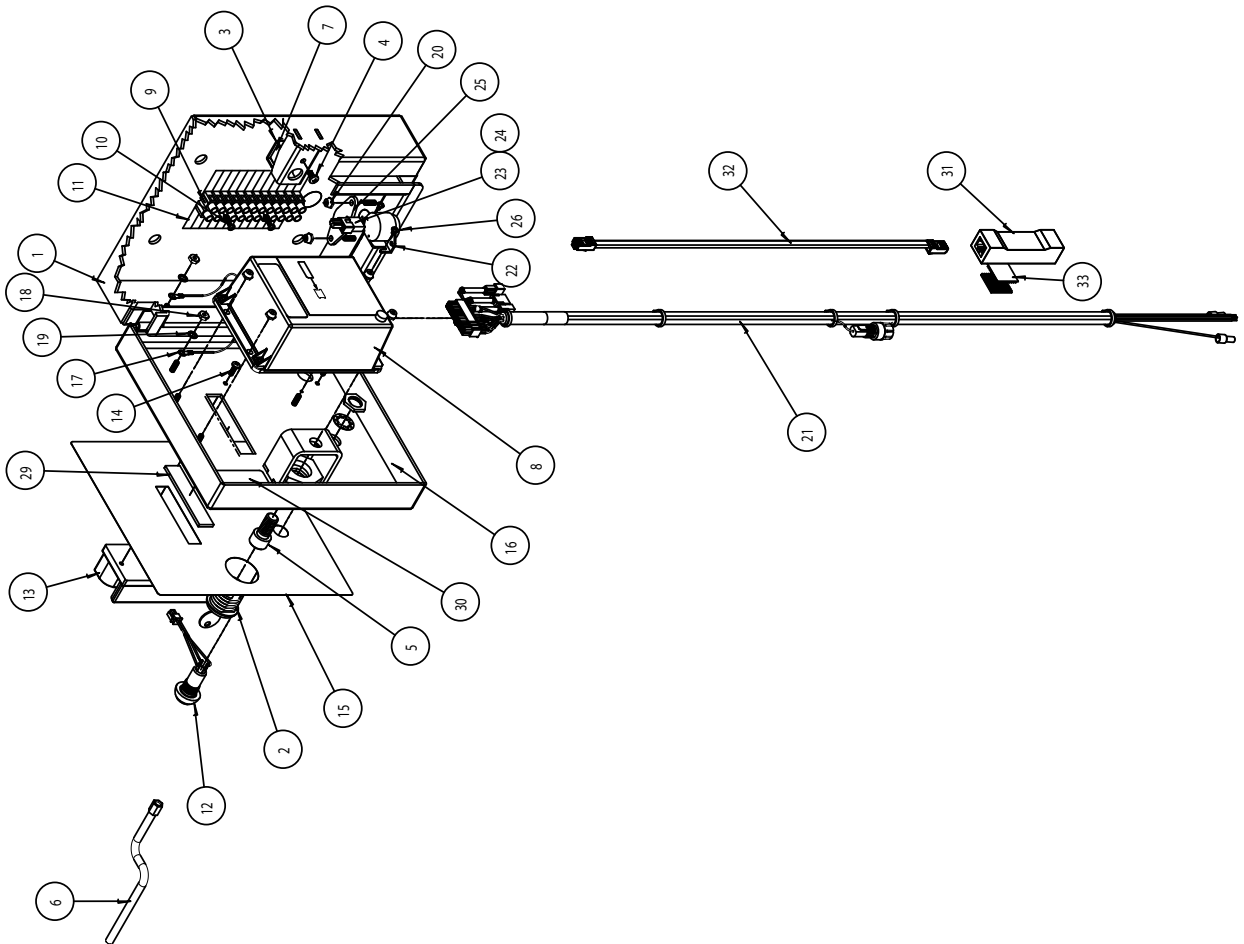
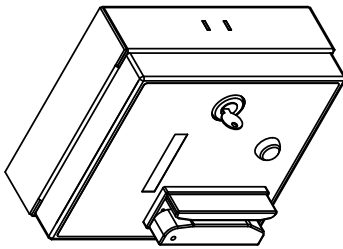

## **With Validator:**

- Disconnect all power routing to existing equipment.
- Using cabinet diagrams determine where to mount the DTT cabinet. Again be sure the selected location is solid.
- Attach the DTT cabinet to selected surface. Follow all applicable local codes.
- Run commercial conduit between the DTT cabinet and existing equipment. Knock out desired opening in the cabinet to allow easy conduit installation.
- You will be pulling a total of eight (8) wires to DTT. Six (6) from the existing equipment and two (2) back to the equipment room.
- An isolated 24v AC power source **MUST** be pulled to the DTT cabinet. This isolated source will power the validator. This can not be the power supply providing power to the existing equipment.
- Using attached wiring schematic make all appropriate wire connections to the DTT terminal strip. All wires in the DTT should be neatly arranged within the DTT cabinet.
- Make all appropriate wire connections inside existing equipment.
- Pull a CAT 5 cable from equipment room to DTT. The CAT 5 can be run within the same conduit.
- Assemble a RJ-45 plug onto the end of the CAT 5 cable.
- Remove the back cover from the controller.
- Attach the CAT 5 plug into the network dataline suppressor.
- Restore power to existing equipment.
- Using handheld and programming manual program timer.
- Replace back cover onto controller.
- Close and lock door to the DTT cabinet.

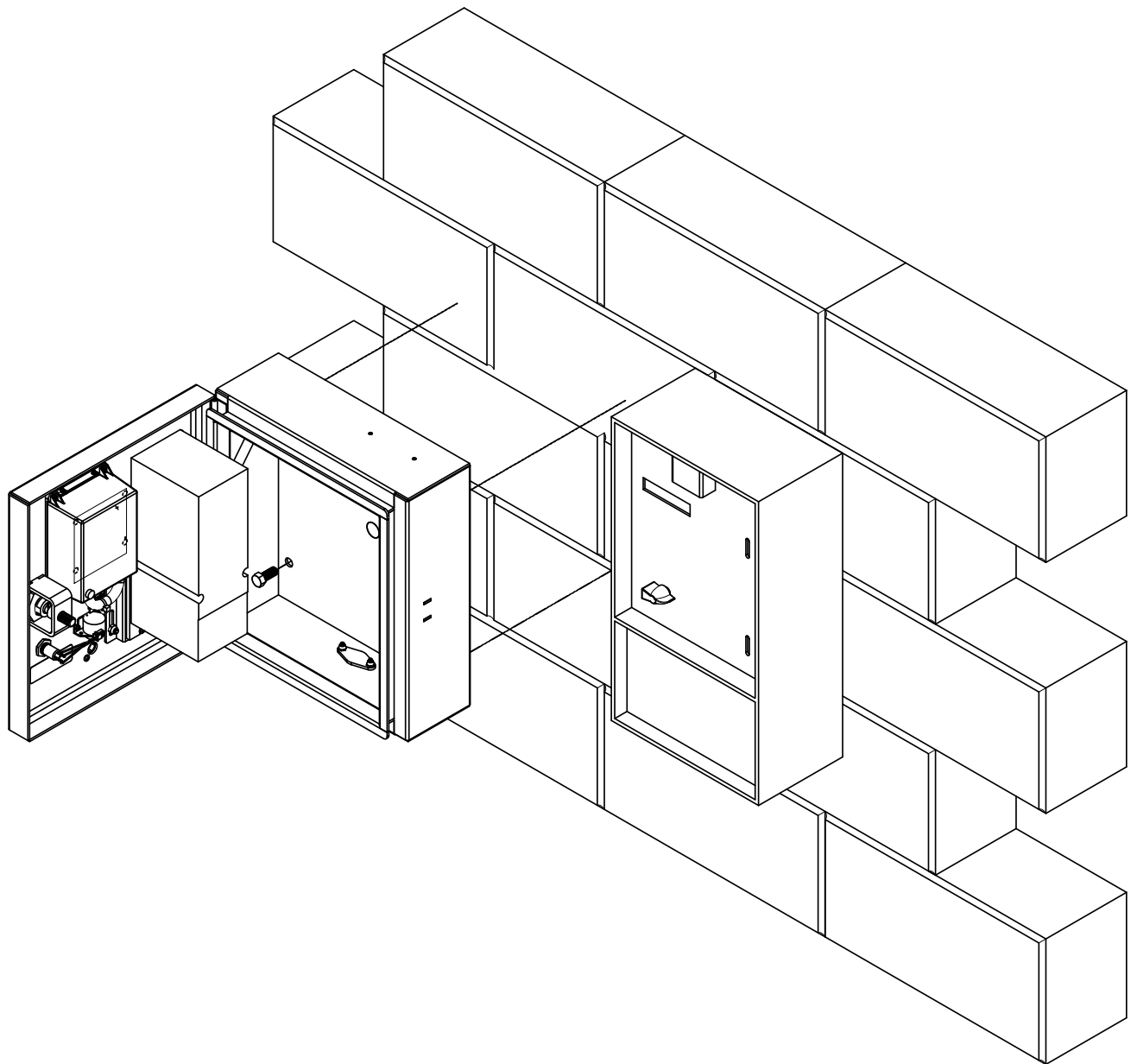

-	1107	E-FACT POST CARD	1
-	101-0173	DTT INSTALLATION MANUAL	1
-	101-0171	DTT PROGRAMMING MANUAL	2
-	96-0092	WARRANTY POST CARD	1
40	90-9089	SELF-LOCK ADHESIVE BACKED TAB 1"x1"	1
39	48-3208	CABLE 20' CAT 5 CABLE	1
38	49-1222	NETWORK DATA LINE SUPPRESSOR	1
37	96-2055	DECAL - GENERAL INFO SMALL	1
36	63-5191	DTT DISPLAY FILLER	1
35	47-0232	CLAMP CABLE PANDUIT	3
34	47-0275	CABLE TIE 6"	3
33	90-0130	SCREW #6-32 x 1/8 PH	2
32	60-2038	HOLE COVER	1
31	49-8532	TERMINAL - FEMALE STANDARD	2
30	49-8531	RECEPTICAL 1X2 STANDARD	1
29	49-9451A	ALARM 12V DC ASSEMBLY	1
28	48-3198	HARNESS DTT DIGITAL	1
27	48-3190	HARNESS DTT COINCO	1
	48-3191	HARNESS DTT MARS	1
	48-3192	HARNESS DTT CASHCODE	1
	46-0213	BILL BOX 300 CASH CODE (CANADA)	
	46-0212	BILL BOX 300 CASH CODE (USA/AUSTRALIA)	
	46-0206	VALIDATOR CASH CODE (USA)	
26	46-0208	VALIDATOR CASH CODE (AUSTRALIA)	1
	46-0204	VALIDATOR CASH CODE (CANADA)	
	46-0211	VALIDATOR MARS 24V 300 BILL BOX	
	46-0169	VALIDATOR COINCO 24V	
25	90-0302	NUT # 10-24 NYLOCK	6
24	90-0145	SCREW #8-32 x 5/8" PH	4
23	60-2318	VALIDATOR ADJUSTOR PLATE	1
22	90-0612	WASHER #10 INTERNAL LOCK	2
21	90-0301	NUT #10-24 x 3/8" HEX	2
20	48-0051A	GROUND STRAP	1
19	47-3012	GASKET - SPONGE RUBBER	4,5
18	90-0341	NUT #1/4-20 NYLOCK	4
17	63-5188	DECAL DTT WITH VALIDATOR	1
16	90-9090	SCREW #3 x 1.0mm PH	2
15	49-9448	CARD READER ID TECH SURFACE MOUNT	1
14	49-9460	ASSEMBLY BUTTON LIGHTED (RED)	1
13	90-0132	SCREW # 6-32 x 1/4" PH	2
12	49-9453A	HEATER ASSEMBLY 30 WATT RESISTIVE	1
11	96-2077	DECAL DTT TERMINAL BLOCK	1
10	90-0032	SCREW # 6-32 x 5/8" PH	4
9	47-3192	TERMINAL BLOCK	1
8	05-0034	DTT CONTROLLER	1
7	90-0335	NUT #1/2-13 SQUARE	1
6	63-5040	LOCK CRANK	1
5	90-0275	LOCK BOLT #1/2-13 x 1"	1
4	90-0148	SCREW # 10-24 x 3/8" PH	1
3	61-2153	BRACKET DOOR LOCK	1
2	63-5001	LOCK SINGLE COMPLETE	1
1	61-2710	CABINET DTT WITH VALIDATOR	1
TERM	PART	RECEPTION	QTY

# DTT-COINCO/ CASHCODE/MARS

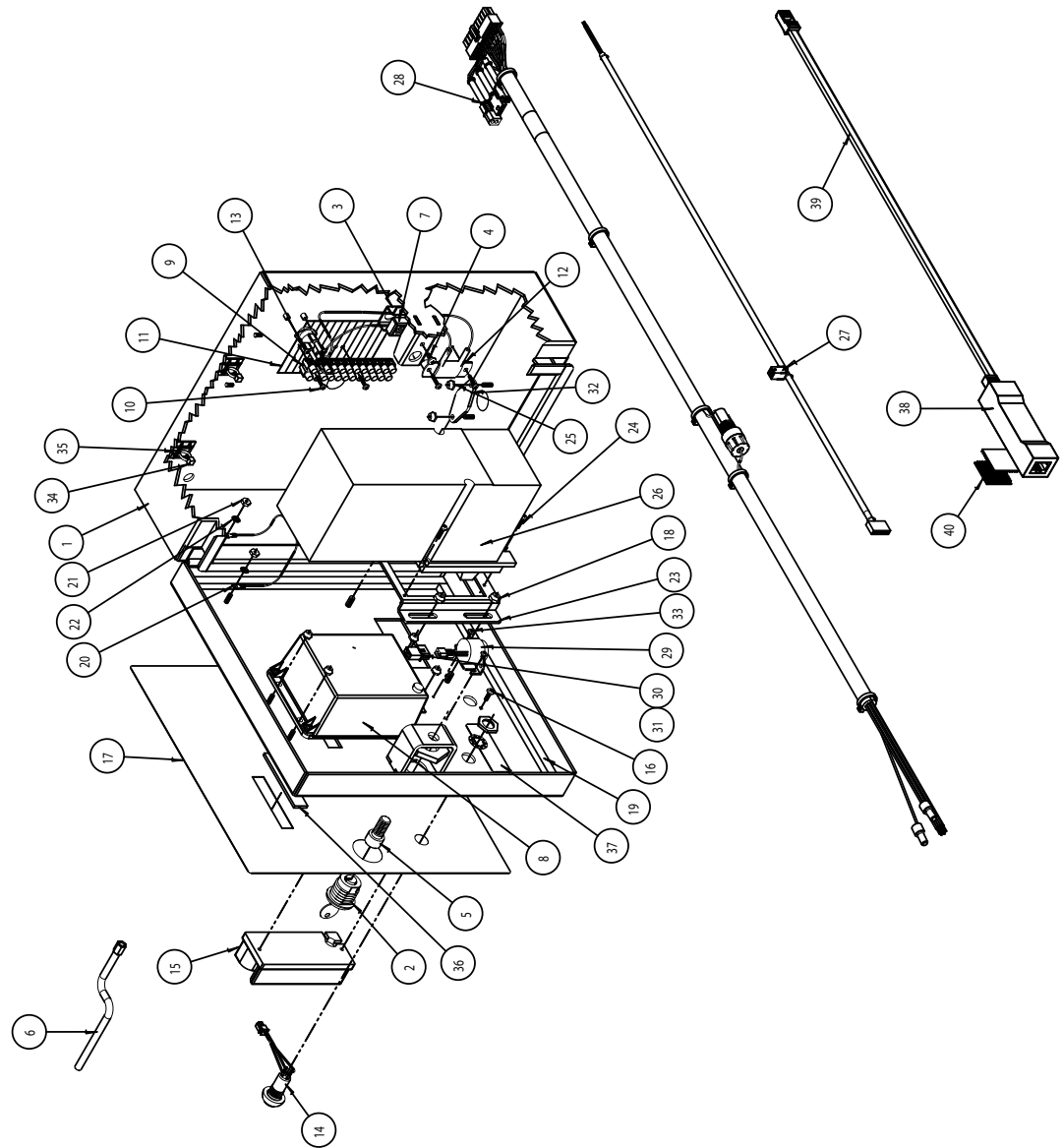



# DTT WIRING

## Terminal Block Connections

MAKE APPRIOPRIATE WIRE  
TERMINATIONS ON THIS SIDE

THIS SIDE SHALL BE WIRED  
WHEN YOU RECIEVE THE UNIT

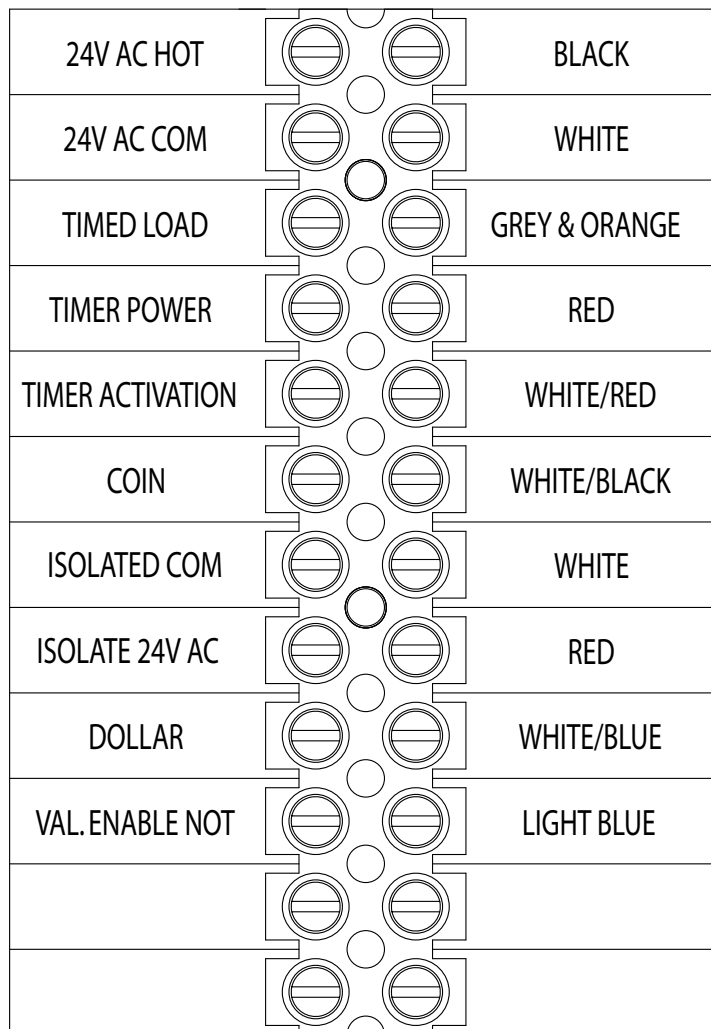

Name	Description
24VAC Hot	Power hot.
24VAC COM	Power and signal common.
Timed Load Sense	Monitors the Timed Load to sense when the selection switch has been energized.
Timer Power (SW 24VAC Hot)	Switched power source for turning the meter box timer on and off.
Timer Activation	
Coin Signal	Monitors the coin signal output of the coin mech.
Isolated COM	
Isolated 24VAC	
Timed Load (SW 24VAC Hot)	Sources power to the selection switch in the meter box

### Switched Timer Power

Pin	Wire Color	Name	Description
1	Black	24VAC Hot	Power hot.
3	White / Black	Coin Signal	Monitors the coin signal output of the coin mech.
7	Grey	Timed Load Sense	Monitors the Timed Load to sense when the selection switch has been energized.
10	Red	Timer Power (SW 24VAC Hot)	Switched power source for turning the meter box timer on and off.
14	White	24VAC COM	Power and signal common.
20	Orange	Timed Load (SW 24VAC Hot)	Sources power to the selection switch in the meter box

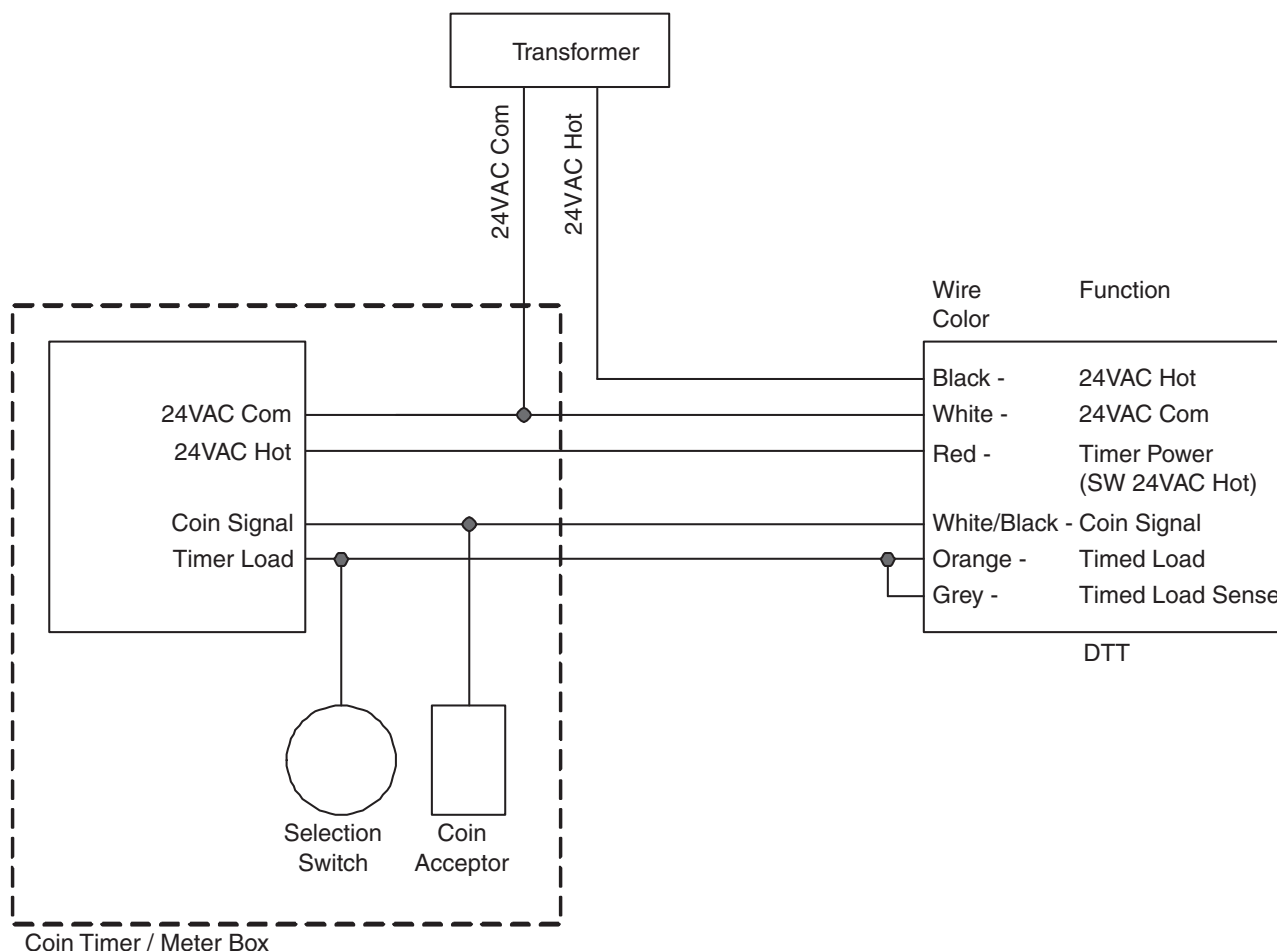

DTT Wiring Diagram - Switched Timer Power

## Timer Activation Input

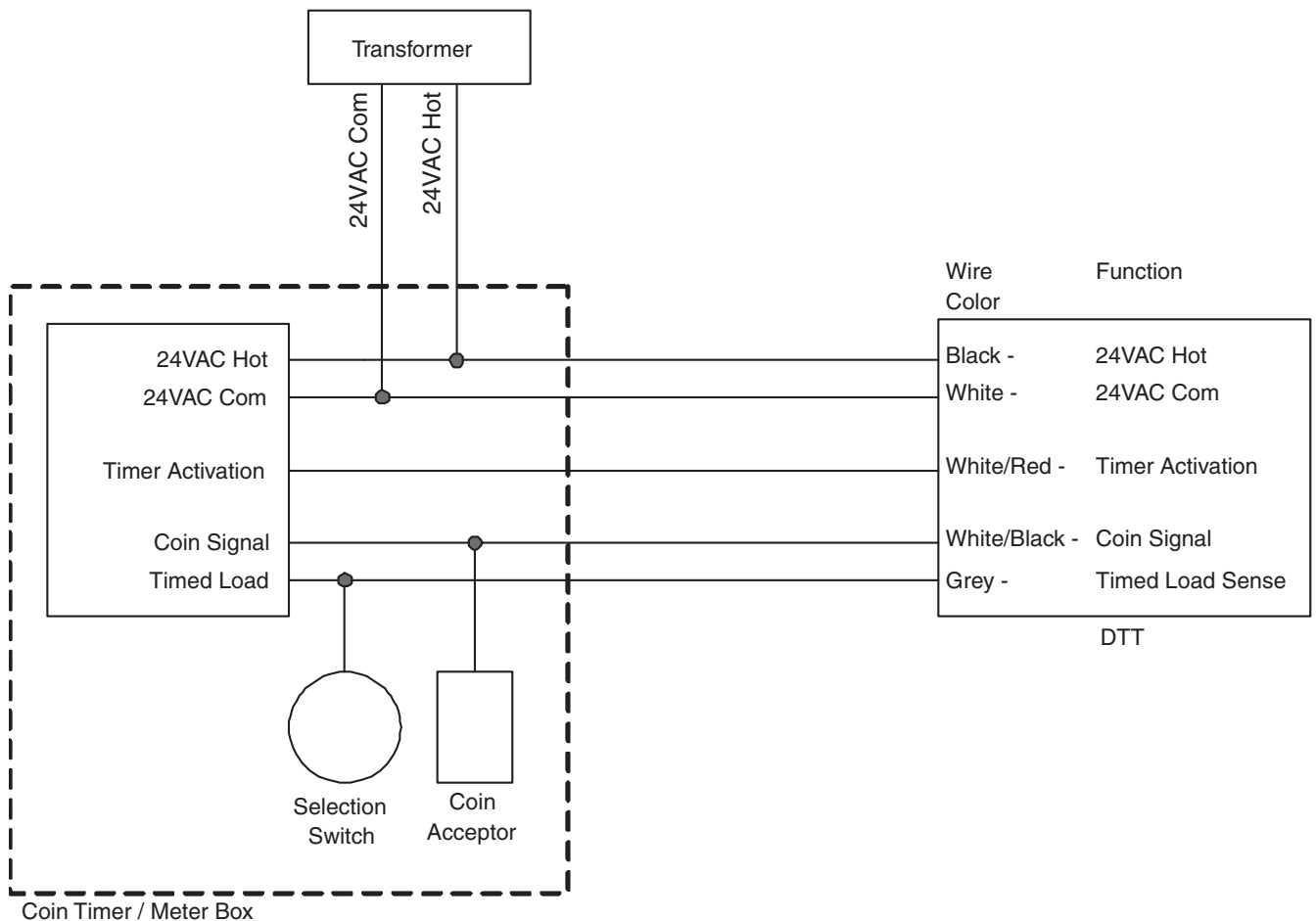

Pin	Wire Color	Name	Description
1	Black	24VAC Hot	Power hot.
3	White / Black	Coin Signal	Monitors the coin signal output of the coin mech.
7	Grey	Timed Load Sense	Monitors the Timed Load to sense when the selection switch has been energized.
12	White / Red	Timer Activation	Some meter box timers have an input that puts the timer into a “count up” mode and powers the selection switch. Use the Timer Activation output to take advantage of this feature.
14	White	24VAC COM	Power and signal common.

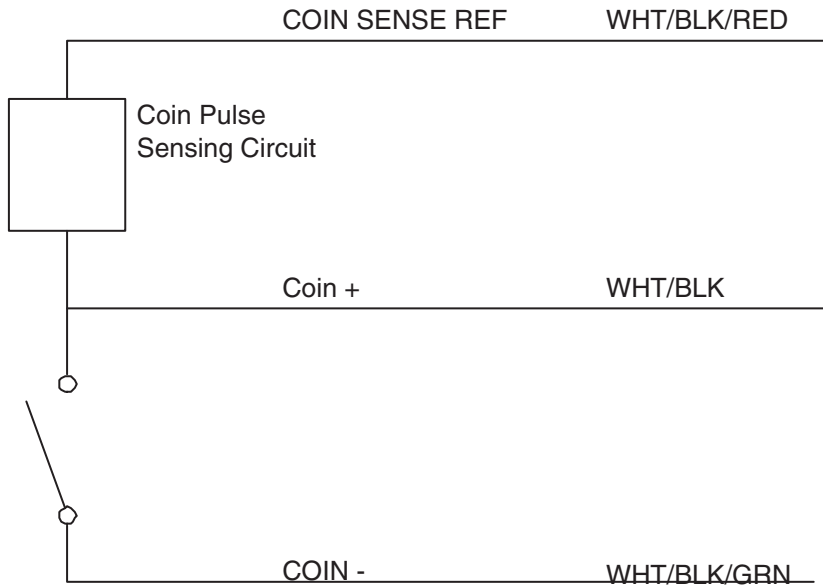

DTT Wiring Diagram - Timer Activation Input

## DTT Coin Circuit Wiring



Function	Wire Color	Positive Pulse Connections 	Negative Pulse Connections 
Coin +	WHT/BLK	Coinmech Coin Line	Coinmech Coin Line
COIN SENSE REF	WHT/BLK/RED	Common	Reference Voltage
COIN -	WHT/BLK/GRN	Reference Voltage	Common

### Reference Voltages

- When the coin pulse is a positive pulse, the WHT/BLK/GRN wire (pin 18) is connected to the desired pulse voltage. For example, if the coin line normally sits at common and switches to 24VAC Hot, the WHT/BLK/GRN wire should be connected to 24VAC Hot.
- When the coin pulse is a negative pulse, the WHT/BLK/RED wire (pin 4) should be connected to a voltage equal to the coin line's steady state voltage. For example, if the coin line normally sits at 24VAC and switches to common, the WHT/BLK/RED wire should be connected to 24VAC Hot.
- The coin circuit is rated for up to 30V AC or DC.
- The Purple wire (pin 19) may be used as a 5VDC reference.
- The Yellow wire (pin 2) may be used as a 12VDC reference for positive pulse systems only.
- When not used, the Yellow and Purple wires should be left capped to prevent accidental shorting.

# MAIN HARNESS

## (48-3198)

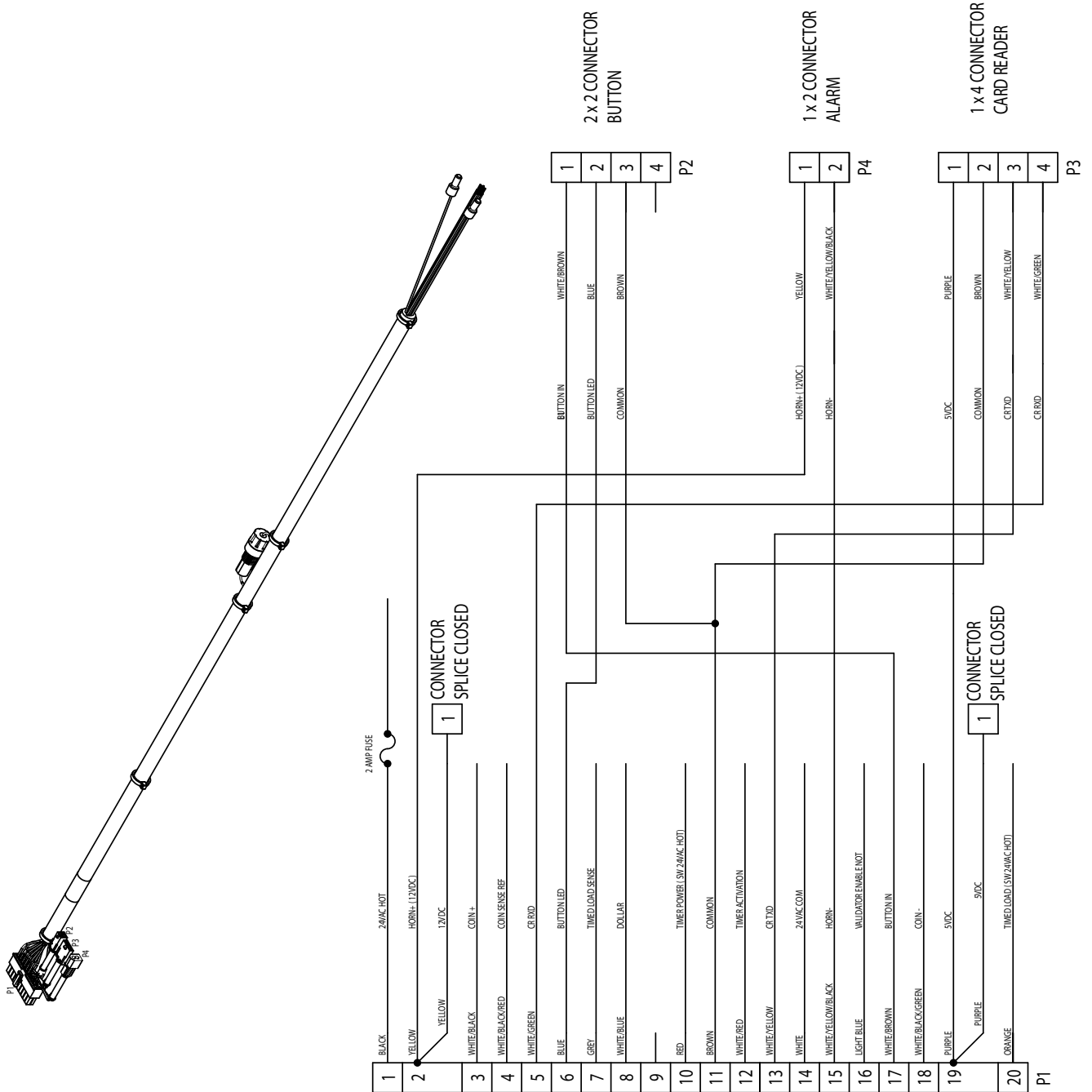

# HARNESS, DTT COINCO (48-3190)

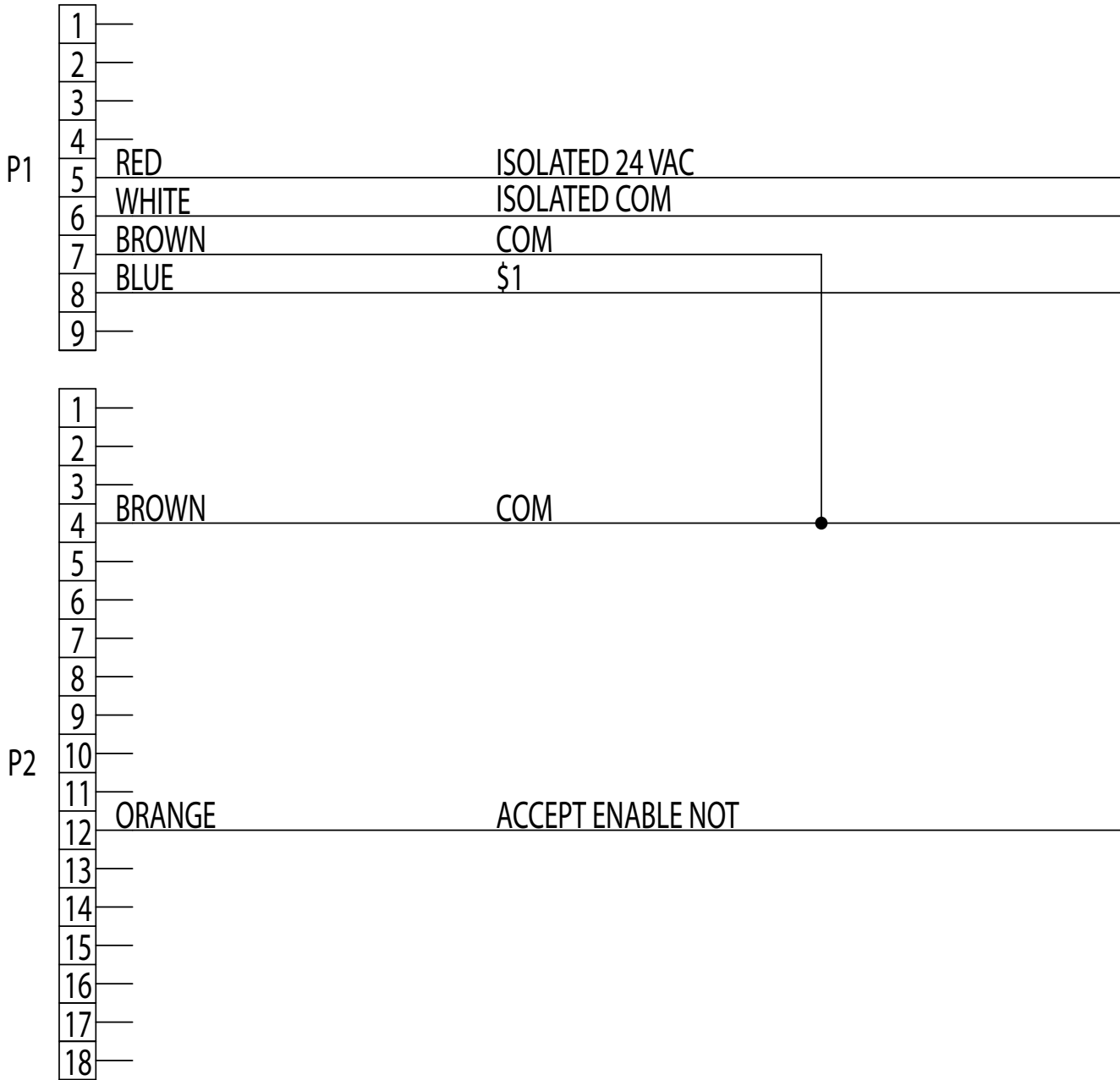
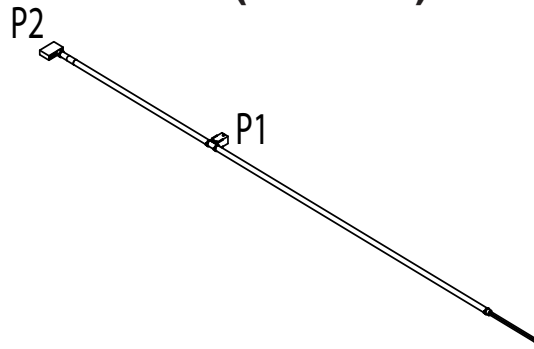

# HARNES, DTT MARS (48-3191)

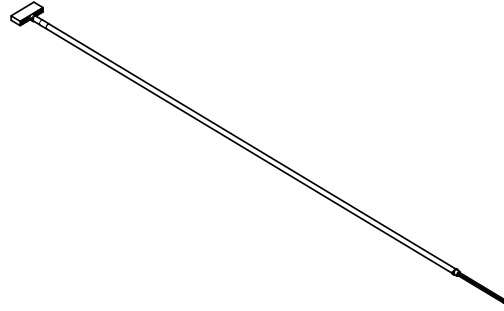

1	BROWN	COM	•
2	BLUE	1\$	•
3	RED	ISOLATED 24 VAC	
4	—		
5	KEY		
6	—		
7	—		
8	—		
9	BROWN	COM	•
10	BROWN	COM	•
11	—		
12	—		
13	—		
14	—		
15	—		
16	—		
17	—		
18	—		
19	—		
20	WHITE	ISOLATED COM	
21	KEY		
22	—		
23	—		
24	ORANGE	ACCEPT ENABLE NOT	
25	—		
26	—		
27	—		
28	—		
29	—		
30	—		

# HARNES, DTT CASHCODE

## (48-3192)

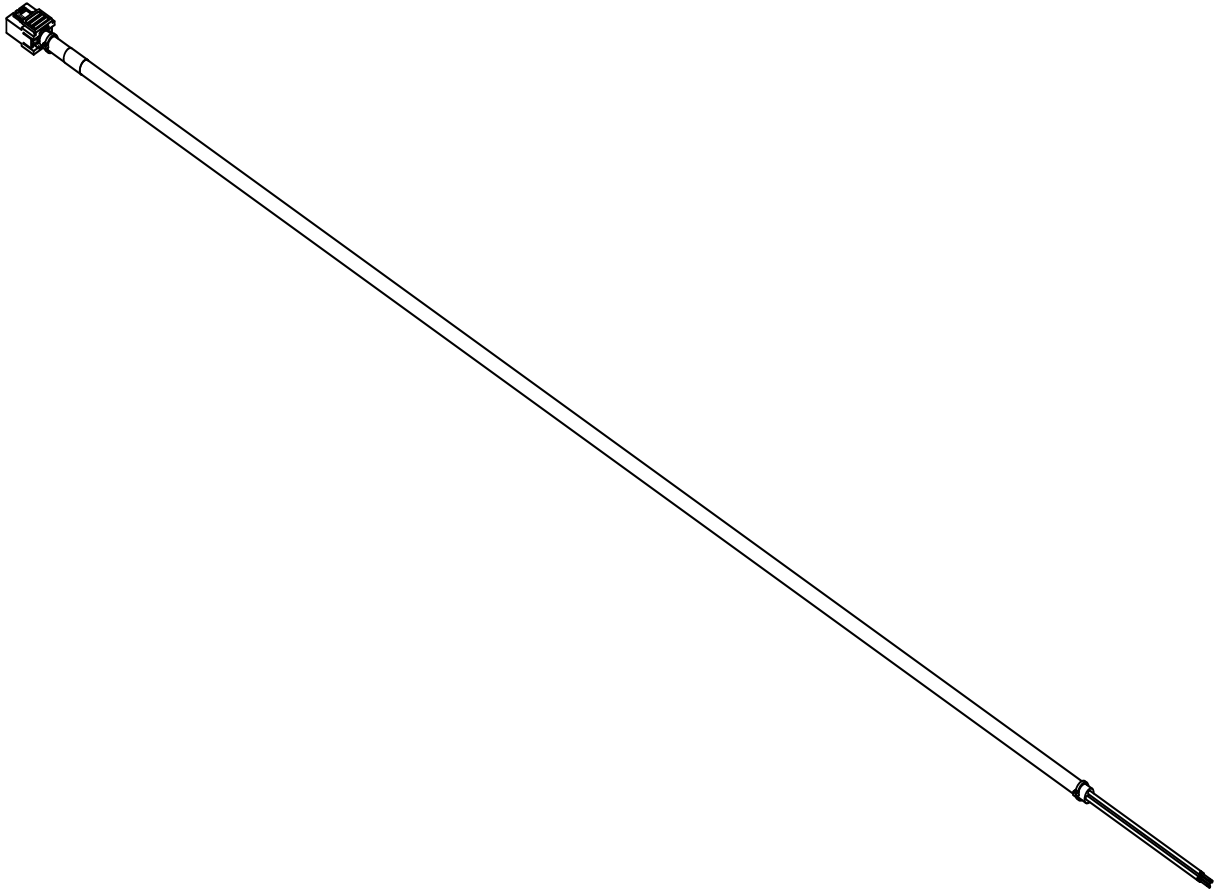

1	WHITE	ISOLATED COMMON
2	RED	ISOLATED 24VAC
3	BROWN	COMMON
4	BLUE	1\$ VEND
5		
6	GREEN	ACCEPT ENABLE
7		
8		

390 Ohm



# LIMITED WARRANTY AGREEMENT OF HAMILTON MANUFACTURING CORP.

Hamilton Manufacturing Corp., an Ohio Corporation, (“Seller”) warrants to Purchaser that all new equipment shall be free from defects in material and factory workmanship for a period of one (1) year from the original shipping date. Hamilton Manufacturing Corp. further warrants if any part of said new equipment in Seller’s sole opinion, requires replacement or repair due to a defect in material or factory workmanship during said period, Seller will repair or replace said new equipment. Purchaser’s remedies and the liabilities and obligations of Seller herein shall be limited to repair or replacement of the equipment as Seller may choose, and Seller’s obligation to remedy such defects shall not exceed the Purchaser’s original cost for the equipment. Purchaser EXPRESSLY AGREES this is the EXCLUSIVE REMEDY under this warranty. There are no other express or implied warranties which extend beyond the face hereof. All warranty repair service must be performed by either a Factory Trained Service Representative or **HAMILTON MANUFACTURING CORP., 1026 Hamilton Drive, Holland, Ohio 43528 PHONE (419) 867-4858 or (800) 837-5561, FAX (419) 867-4867.**

The limited warranty for new equipment is conditioned upon the following:

1. The subject equipment has not, in the Seller’s sole opinion, been subjected to: accident, abuse, misuse, vandalism, civil disobedience, riots, acts of God, natural disaster, acts of war or terrorism.
2. The Seller shall not be liable for any expense incurred by Purchaser incidental to the repair or replacement of equipment and Purchaser shall assume full responsibility for any freight or shipping charges.
3. The coverage of this warranty shall not extend to expendable parts.
4. Purchaser shall have a warranty registration card on file with Seller prior to any claim in order for warranty protection to apply.
5. No warranty coverage is applicable to any equipment used for currency other than that specified at the time of the purchase.
6. Seller expressly disclaims any warranty that counterfeit currency will not activate said equipment.
7. Seller expressly disclaims any warranty for any losses due to bill manipulation or theft or loss of cash under any circumstances.
8. Use of the equipment for anything other than its intended and designed use will void the Limited Warranty Agreement. Use of equipment for anything other than its intended and designed use includes, but is not limited to, downloading software/applications not certified by Seller such as e-mail, spyware, screen savers, viruses, worms, third party software, web search engines, cookies, spam, desktop applications, games, web surfing, etc.

Seller further warrants all repair or service work performed by a factory trained representative or Hamilton Manufacturing Corp. for a period of ninety (90) days from the date the repair or service work was performed. Purchaser’s remedies and the liabilities and obligations of Seller herein shall be limited to repair or replacement of equipment as Seller may choose, and Seller’s obligation to remedy such defects shall not exceed the Purchaser’s depreciated value of the equipment. Purchaser EXPRESSLY AGREES this is an EXCLUSIVE REMEDY under this warranty. There are no other express or implied warranties on repair or service work performed by a factory trained representative or Hamilton Manufacturing Corp. which extend beyond the face hereof.

The limited warranty for repair and service work is conditioned upon the following:

1. The subject equipment has not, in the Seller's sole opinion, been subjected to: accident, abuse, misuse, vandalism, civil disobedience, riots, acts of God, natural disaster, acts of war or terrorism.
2. The Seller shall not be liable for any expense incurred by Purchaser incidental to the repair or replacement of equipment and Purchaser shall assume full responsibility for any freight or shipping charges.
3. The coverage of this warranty shall not extend to expendable parts.
4. Purchaser shall have a warranty registration card on file with Seller prior to any claim in order for warranty protection to apply.
5. No warranty coverage is applicable to any equipment used for currency other than that specified at the time of the purchase.
6. Seller expressly disclaims any warranty that counterfeit currency will not activate said equipment.
7. Seller expressly disclaims any warranty for any losses due to bill manipulation or theft or loss of cash under any circumstances.
8. No person or entity other than a factory trained representative or Hamilton Manufacturing Corp. has performed or attempted to perform the subject repair or service.
9. Using equipment which has been serviced or repaired for anything other than its intended or designed use such as downloading software applications not certified by Seller will void the Limited Warranty Agreement. This includes software/applications such as e-mail, spyware, screen savers, viruses, worms, third party software, web search engines, cookies, spam, desktop applications, games, web surfing, etc.

THIS AGREEMENT IS MADE WITH THE EXPRESS UNDERSTANDING THAT THERE ARE NO IMPLIED WARRANTIES THAT THE EQUIPMENT SHALL BE MERCHANTABLE, OR THAT THE GOODS SHALL BE FIT FOR ANY PARTICULAR PURPOSE. PURCHASER HEREBY ACKNOWLEDGES THAT IT IS NOT RELYING ON THE SELLER'S SKILL OR JUDGMENT TO SELECT OR FURNISH EQUIPMENT SUITABLE FOR ANY PARTICULAR PURPOSE AND THAT THERE ARE NO WARRANTIES WHICH EXTEND BEYOND THAT WHICH IS DESCRIBED HEREIN.

The Purchaser agrees that in no event will the Seller be liable for direct, indirect, or consequential damages or for injury resulting from any defective or non-conforming new, repaired or serviced equipment, or for any loss, damage or expense of any kind, including loss of profits, business interruption, loss of business information or other pecuniary loss arising in connection with this Limited Warranty Agreement, or with the use of, or inability to use the subject equipment regardless of Sellers knowledge of the possibility of the same.



# **Hamilton Manufacturing Corp.**

1026 Hamilton Drive  
Holland, OH 43528

**Sales Phone:** (888) 723-4858    **Sales Fax:** (419) 867-4850  
**Customer Service Phone:** (800) 837-5561    **Customer Service Fax:** (419) 867-4857  
**Parts Phone:** (866) 835-1721    **Parts Fax:** (419) 867-4867

**Website:** <http://www.hamiltonmfg.com>

**Email Addresses:**

[service@hamiltonmfg.com](mailto:service@hamiltonmfg.com)

[sales@hamiltonmfg.com](mailto:sales@hamiltonmfg.com)

[parts@hamiltonmfg.com](mailto:parts@hamiltonmfg.com)